



**HOW TO BUILD
TECHNO MODULE**

MODULAR
ELSTEEL
ENCLOSURES

Lets take you through how to efficiently build a
Techno Module panel board!

We've kept it easy and stuck with the basics and a few tips and tricks, as well
as a selection of Cu connections with the major circuit breaker brands.

These are only the basic steps. For more detailed guidance, please set up a
training session with your supplier of Techno Module.

Its important that you get in depth training since the end product
you deliver will be your responsibility and this is only meant as a guide.
We also recommend that you check out the Constructors Manual online at
www.elsteel.com

We've already attached the screws and brackets in as many parts as possible
to its easy for you to unpack and assemble.

If you keep all the parts and your tools ready at hand before you start,
it'll be quick and easy!

Have fun!



You're holding a top of the line
quality product in your hands.
Made with love and excellence!
I hope you will enjoy assembling and
using Elsteel products as much as
I enjoy manufacturing it for you.

A stylized, handwritten signature in black ink, appearing to be 'Fang Logstrup'.

Fang Logstrup
Managing Director

CONTENTS

PAGES

1. How to build basic Techno Module / Techno Module Light frame	03 - 20
2. How to transport and install the Techno Module panel	21 - 24
3. How to build the main busbar system	25 - 36
4. How to build the main busbar system in 'L' shape panel	37 - 44
5. How to assemble Interlock mechanism of the Plug & Power fully withdrawable unit	45 - 46
6. How to build Techno Module Light Panel	47 - 50

①

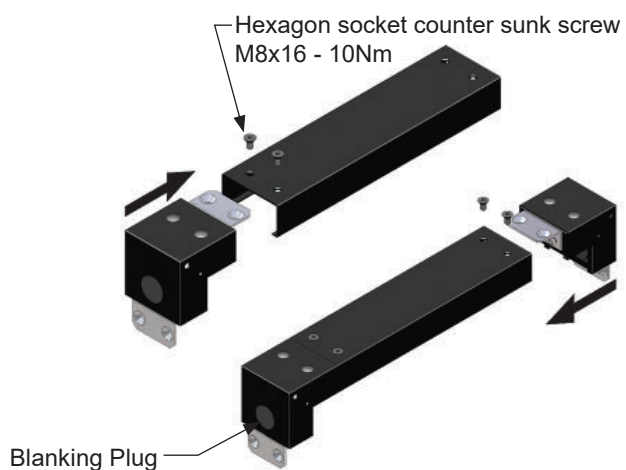

②

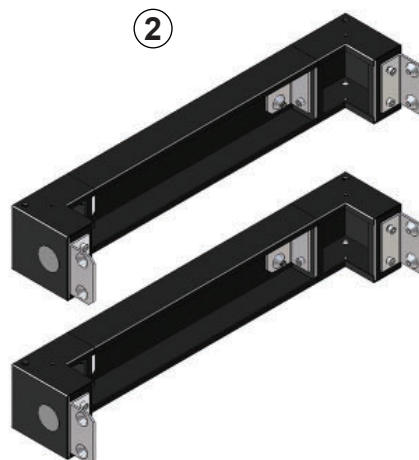

③

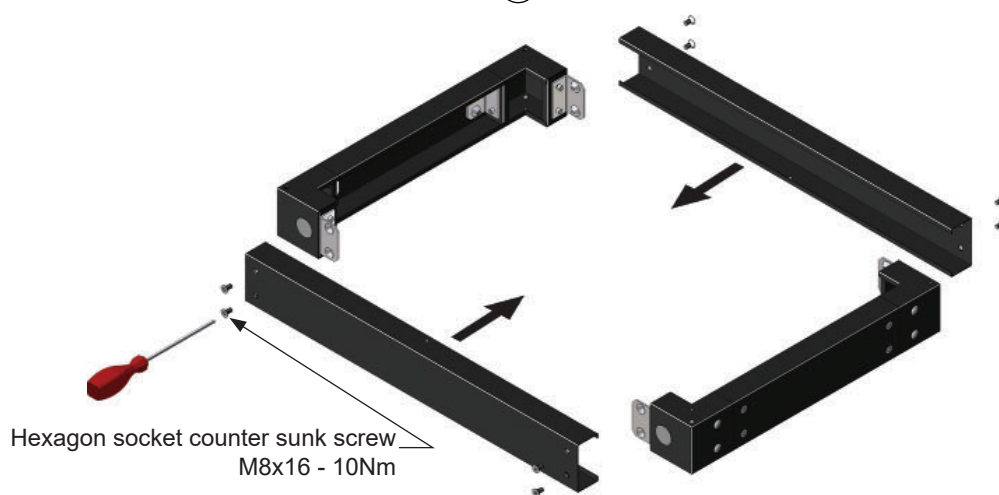

④

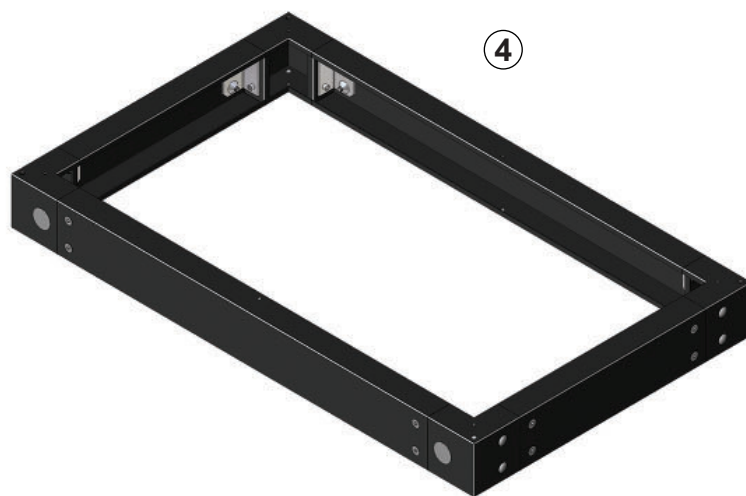

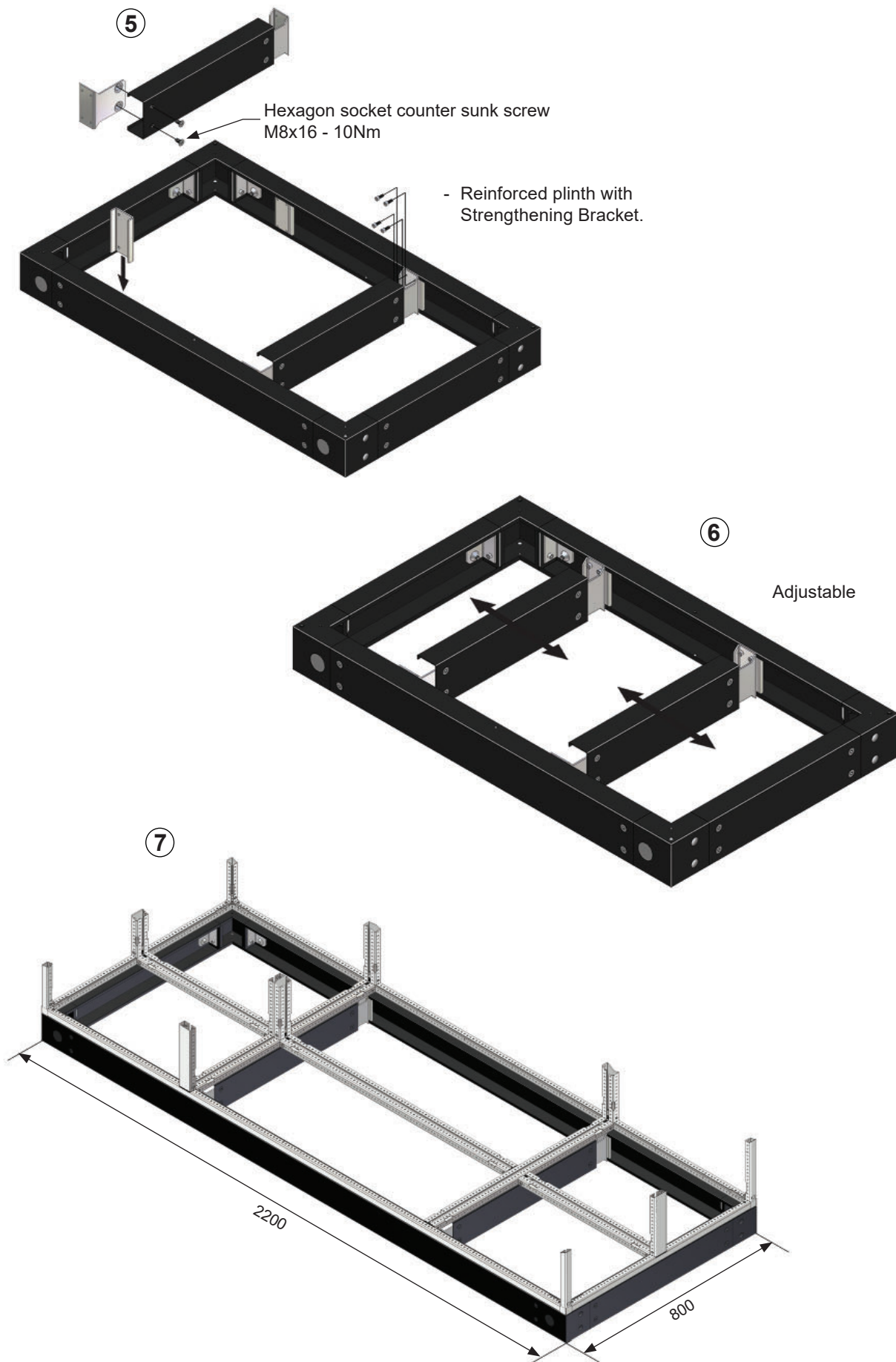

Note : Please refer page no.19 for Floor Mounting.

HEAVY DUTY PLINTH

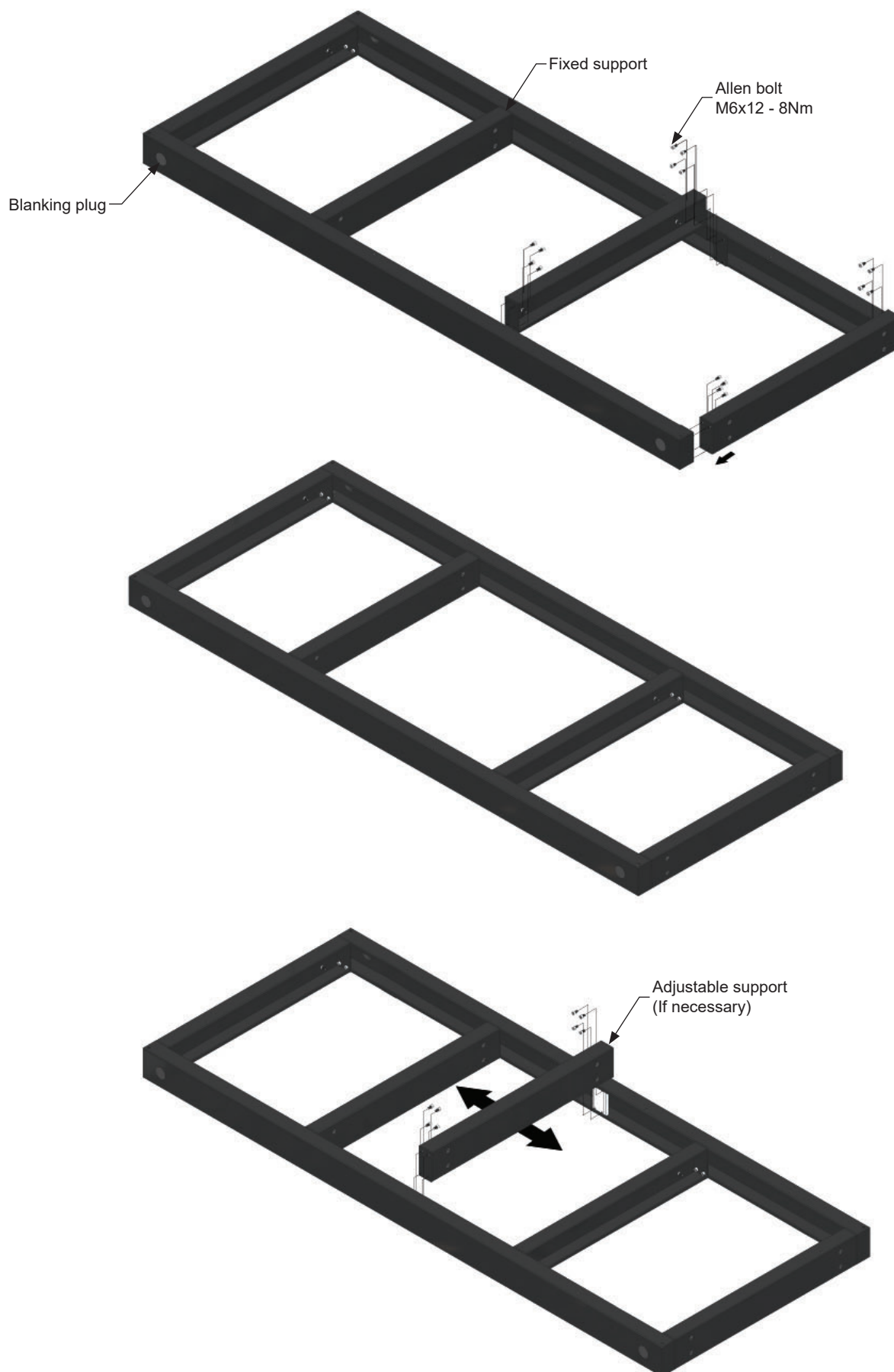

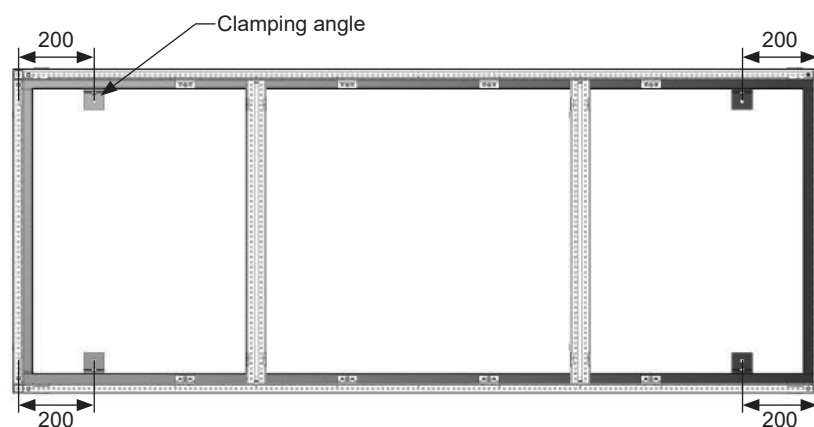
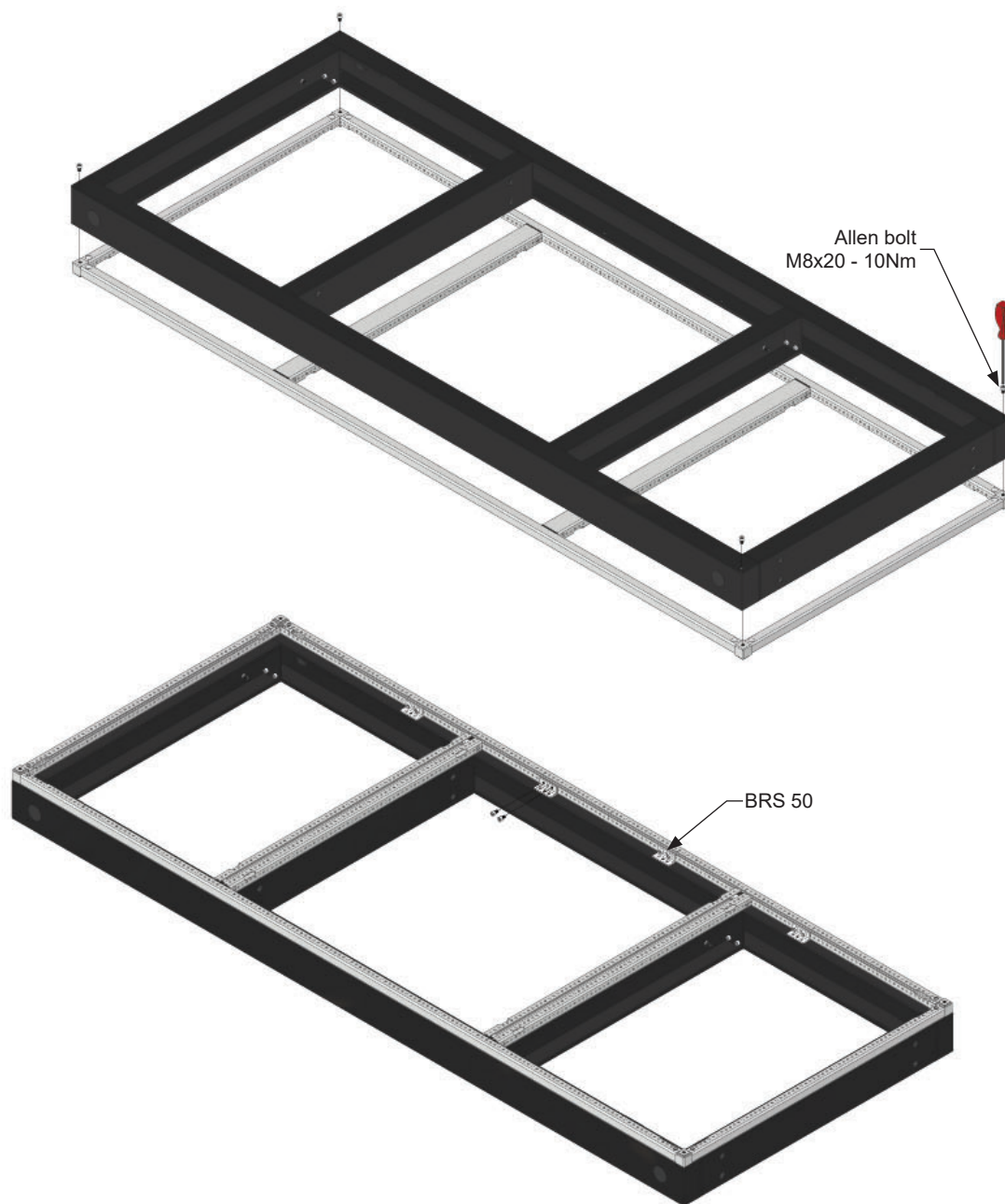

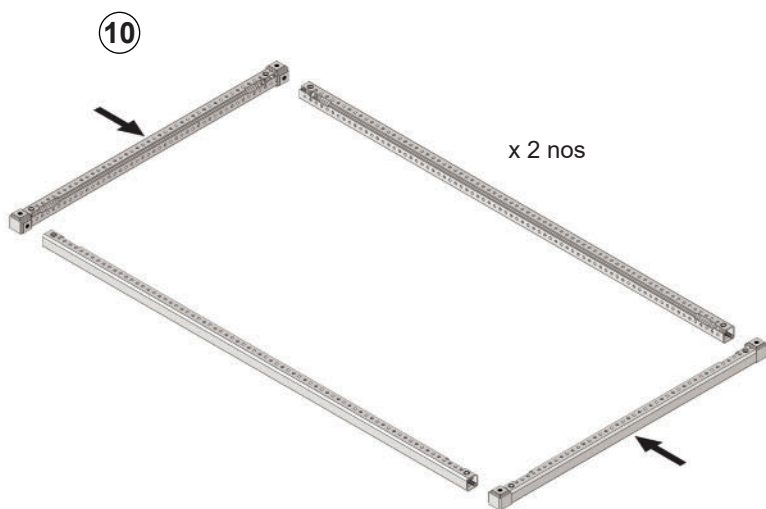
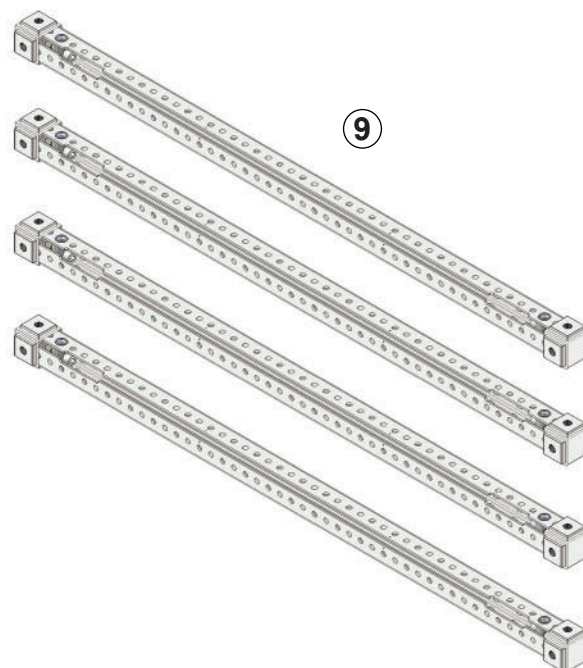
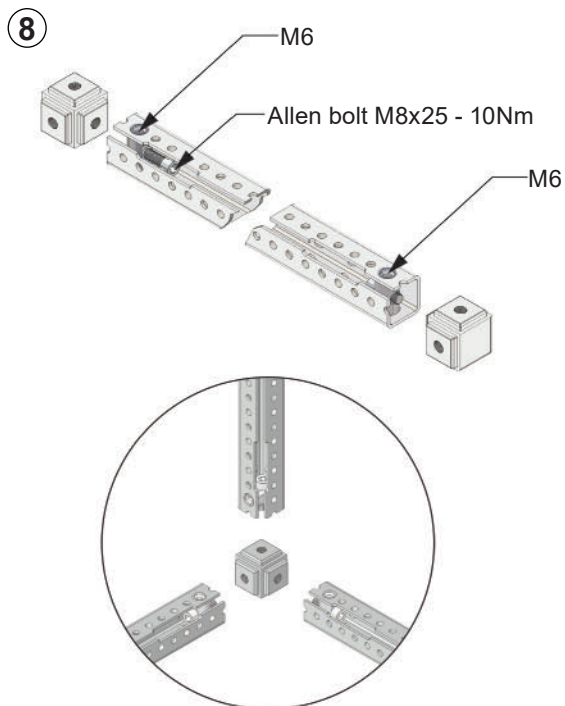

Tip !
It's easier to align the holes,
if you do the assembly on a work top.

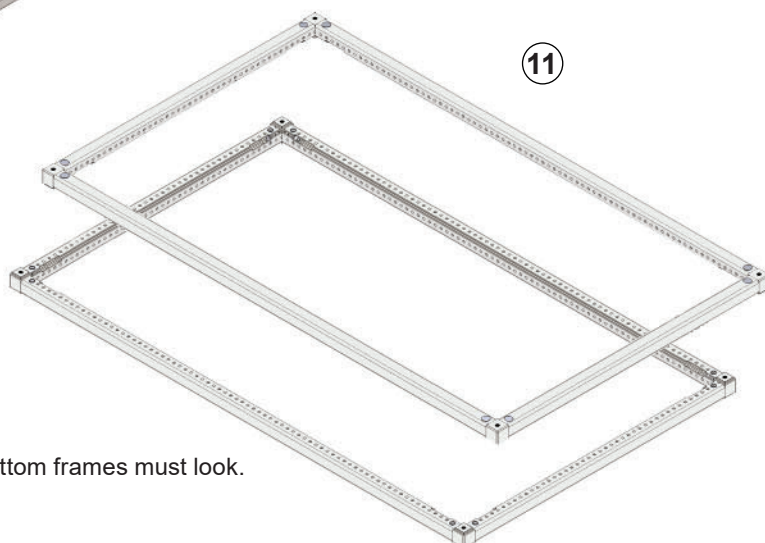

- This is how the top and bottom frames must look.

12

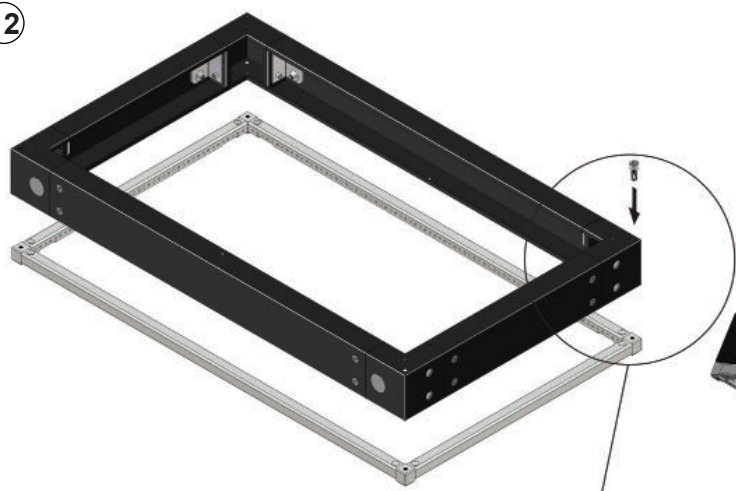

Allen bolt M8x20 - 10Nm

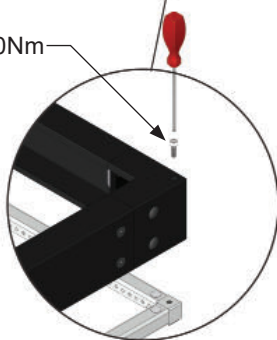

13

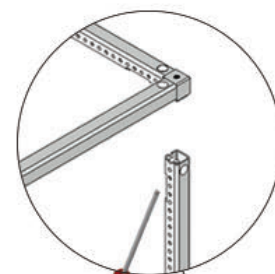

10Nm

14

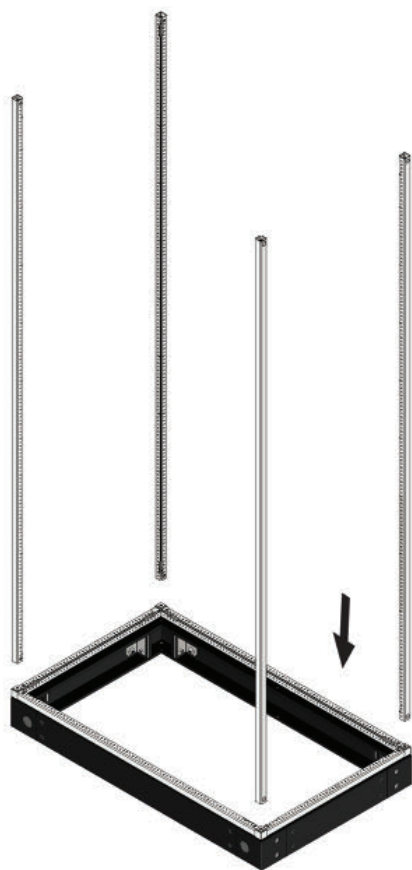

15

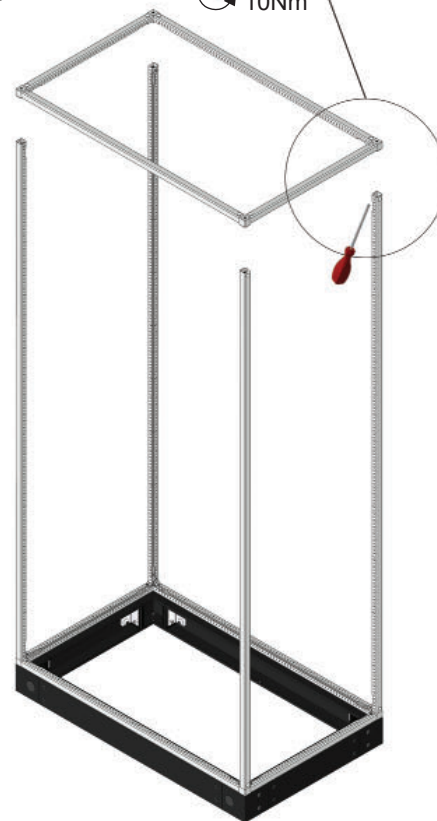

- Place the base on the floor and fix the top frame to the corner bars

CROSS BAR

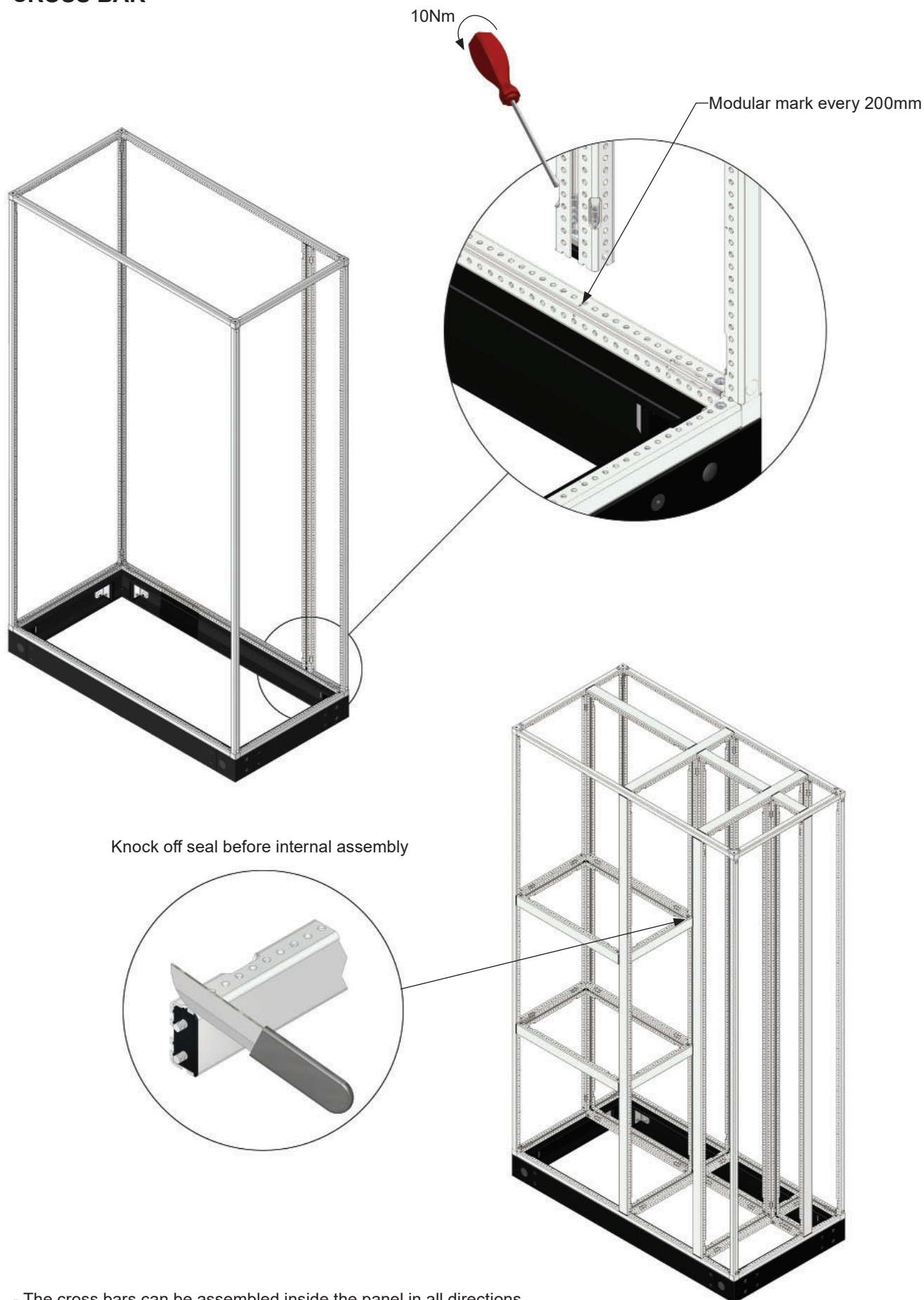

- The cross bars can be assembled inside the panel in all directions.

FIXING

- Fix hinges, cam receivers and fixing brackets for the doors and covers. All parts are packed with the doors and covers. Doors can be fitted hinged left or right. All cover fixings and door hinges should be fitted during the basic build process, to ensure these fixing positions are not used when fitting other internal components.

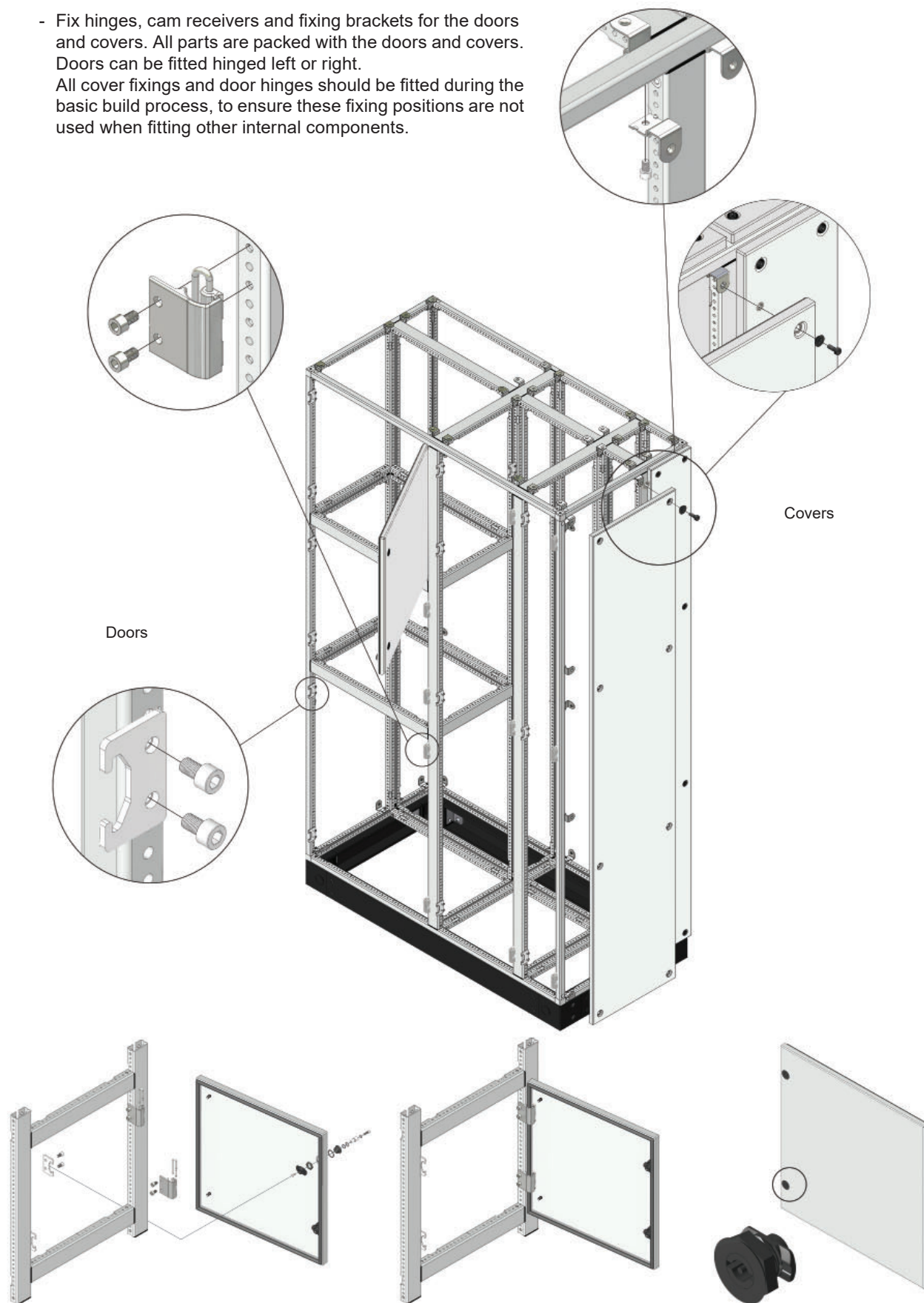

- All the M6 bolts in the system must be tightened to 10Nm.
- See the constructors manual for other type locks.

Version 2

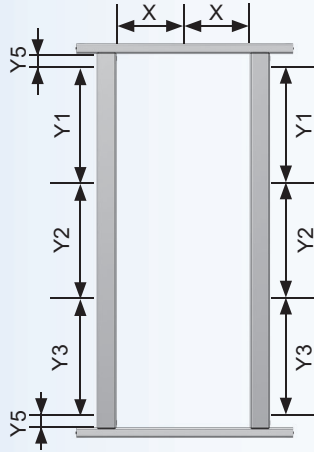

DOOR ■
CAM RECEIVER & HINGE POSITION

TYPE	NUMBER OF CAM RECEIVERS	X	Y ₁	Y ₂	Y ₃	Y ₅
DO 2.2	1	-	100	-	-	75
DO 2.4	2	-	200	-	-	75
DO 2.6	2	-	400	-	-	75
DO 2.8	3	-	300	300	300	75
DO 2.10	3	-	400	400	400	75
DO 2.12	3	-	500	500	500	75
DO 2.14	3	-	600	600	600	75
DO 2.16	4	-	400	600	400	75
DO 2.18	4	-	500	600	500	75
DO 2.20	4	-	600	600	600	75
DO 2.22	4	-	700	600	700	75
DO 4.2	1	-	100	-	-	75
DO 4.3	1	-	100	-	-	125
DO 4.4	2	-	200	-	-	75
DO 4.6	2	-	400	-	-	75
DO 4.8	3	-	300	300	300	75
DO 4.10	3	-	400	400	400	75
DO 4.12	3	-	500	500	500	75
DO 4.14	3	-	600	600	600	75
DO 4.16	4	-	400	600	400	75
DO 4.18	4	-	500	600	500	75
DO 4.20	4	-	600	600	600	75
DO 4.22	4	-	700	600	700	75
DO 6.2	1	-	100	-	-	75
DO 6.3	1	-	100	-	-	125
DO 6.4	2	-	200	-	-	75
DO 6.6	2	-	400	-	-	75
DO 6.8	3	-	300	-	300	75
DO 6.10	3	-	400	-	400	75
DO 6.12	3	-	500	-	500	75
DO 6.14	3	-	600	-	600	75
DO 6.16	4	-	400	600	400	75
DO 6.18	4	-	500	600	500	75
DO 6.20	4	-	600	600	600	75
DO 6.22	4	-	700	600	700	75
DO 8.4	2	-	200	-	-	75
DO 8.6	2	-	400	-	-	75
DO 8.8	3	-	300	-	300	75
DO 8.10	3	-	400	-	400	75
DO 8.12	3	-	500	-	500	75
DO 8.14	3	-	600	-	600	75
DO 8.16	4	-	400	600	400	75
DO 8.18	4	-	500	600	500	75
DO 8.20	4	-	600	600	600	75
DO 8.22	4	-	700	600	700	75
DO 10.10	5	475	400	400	-	75
DO 10.12	5	475	500	500	-	75
DO 10.14	5	475	600	600	-	75
DO 10.16	6	475	400	600	400	75
DO 10.18	6	475	500	600	-	75
DO 10.20	6	475	600	600	600	75
DO 10.22	6	475	700	600	700	75
DO 12.10	5	575	400	400	-	75
DO 12.12	5	575	500	500	-	75
DO 12.14	5	575	600	600	-	75
DO 12.16	6	575	400	600	400	75
DO 12.18	6	575	500	600	500	75
DO 12.20	6	575	600	600	600	75
DO 12.22	6	575	700	600	700	75

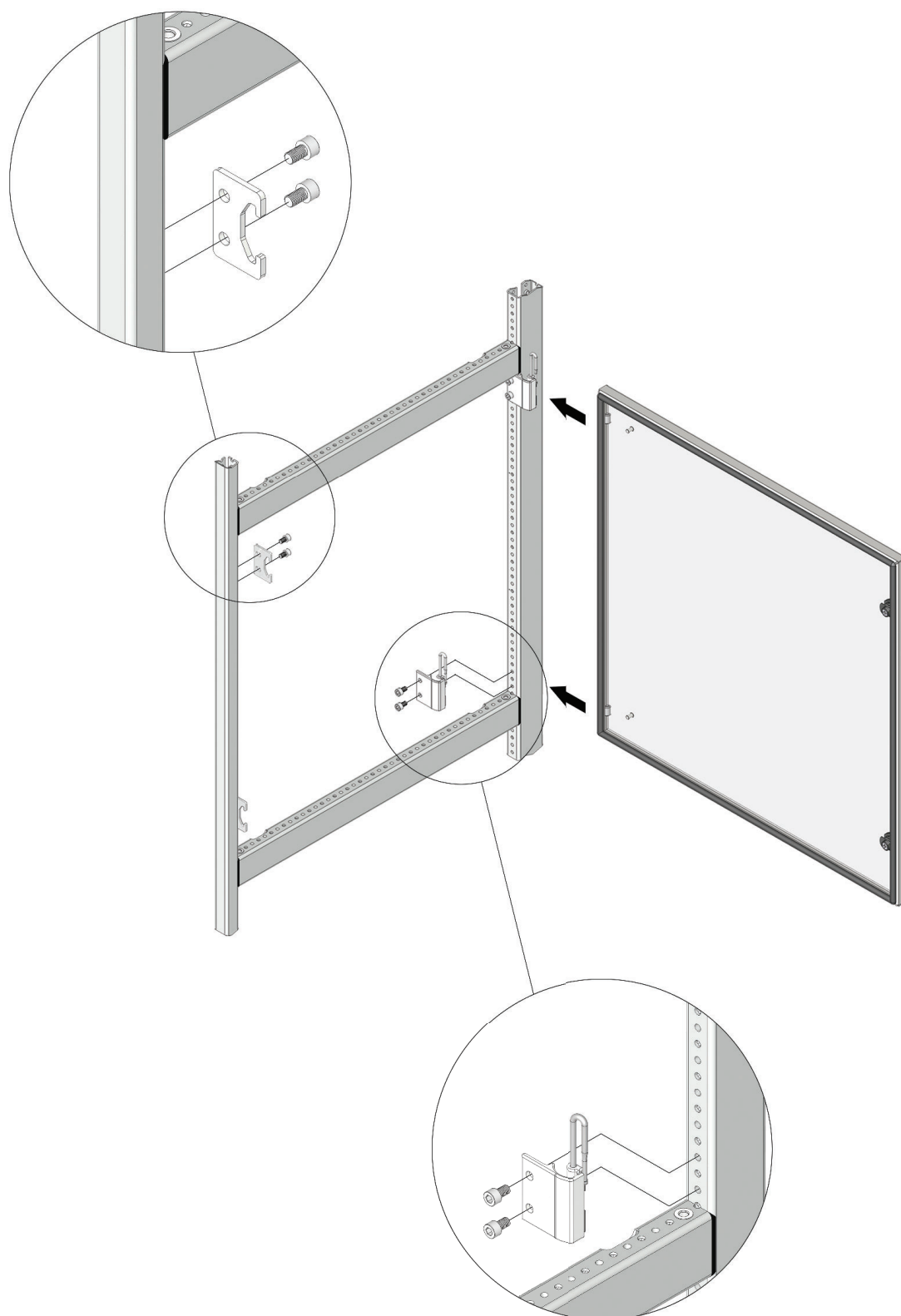

Version 3

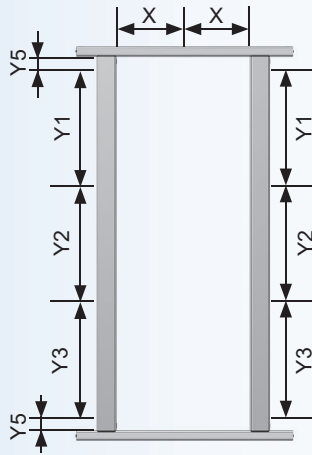

DOOR ■
CAM RECEIVER POSITION

TYPE	NUMBER OF CAM RECEIVERS	X	Y ₁	Y ₂	Y ₃	Y ₅
DO 2.2	1	-	100	-	-	75
DO 2.4	2	-	200	-	-	75
DO 2.6	2	-	400	-	-	75
DO 2.8	3	-	300	-	300	75
DO 2.10	3	-	400	400	400	75
DO 2.12	3	-	500	500	500	75
DO 2.14	3	-	600	600	600	75
DO 2.16	4	-	400	600	400	75
DO 2.18	4	-	500	600	500	75
DO 2.20	4	-	600	600	600	75
DO 2.22	4	-	700	600	700	75
DO 4.2	1	-	100	-	-	75
DO 4.3	1	-	100	-	-	125
DO 4.4	2	-	200	-	-	75
DO 4.6	2	-	400	-	-	75
DO 4.8	3	-	300	300	300	75
DO 4.10	3	-	400	400	400	75
DO 4.12	3	-	500	500	500	75
DO 4.14	3	-	600	600	600	75
DO 4.16	4	-	400	600	400	75
DO 4.18	4	-	500	600	500	75
DO 4.20	4	-	600	600	600	75
DO 4.22	4	-	700	600	700	75
DO 6.2	1	-	100	-	-	75
DO 6.3	1	-	100	-	-	125
DO 6.4	2	-	200	-	-	75
DO 6.6	2	-	400	-	-	75
DO 6.8	3	-	300	-	300	75
DO 6.10	3	-	400	-	400	75
DO 6.12	3	-	500	-	500	75
DO 6.14	3	-	600	-	600	75
DO 6.16	4	-	400	600	400	75
DO 6.18	4	-	500	600	500	75
DO 6.20	4	-	600	600	600	75
DO 6.22	4	-	700	600	700	75
DO 8.4	2	-	200	-	-	75
DO 8.6	2	-	400	-	-	75
DO 8.8	3	-	300	-	300	75
DO 8.10	3	-	400	-	400	75
DO 8.12	3	-	500	-	500	75
DO 8.14	3	-	600	-	600	75
DO 8.16	4	-	400	600	400	75
DO 8.18	4	-	500	600	500	75
DO 8.20	4	-	600	600	600	75
DO 8.22	4	-	700	600	700	75
DO 10.10	5	475	400	400	-	75
DO 10.12	5	475	500	500	-	75
DO 10.14	5	475	600	600	-	75
DO 10.16	6	475	400	600	400	75
DO 10.18	6	475	500	600	-	75
DO 10.20	6	475	600	600	600	75
DO 10.22	6	475	700	600	700	75
DO 12.10	5	575	400	400	-	75
DO 12.12	5	575	500	500	-	75
DO 12.14	5	575	600	600	-	75
DO 12.16	6	575	400	600	400	75
DO 12.18	6	575	500	600	500	75
DO 12.20	6	575	600	600	600	75
DO 12.22	6	575	700	600	700	75

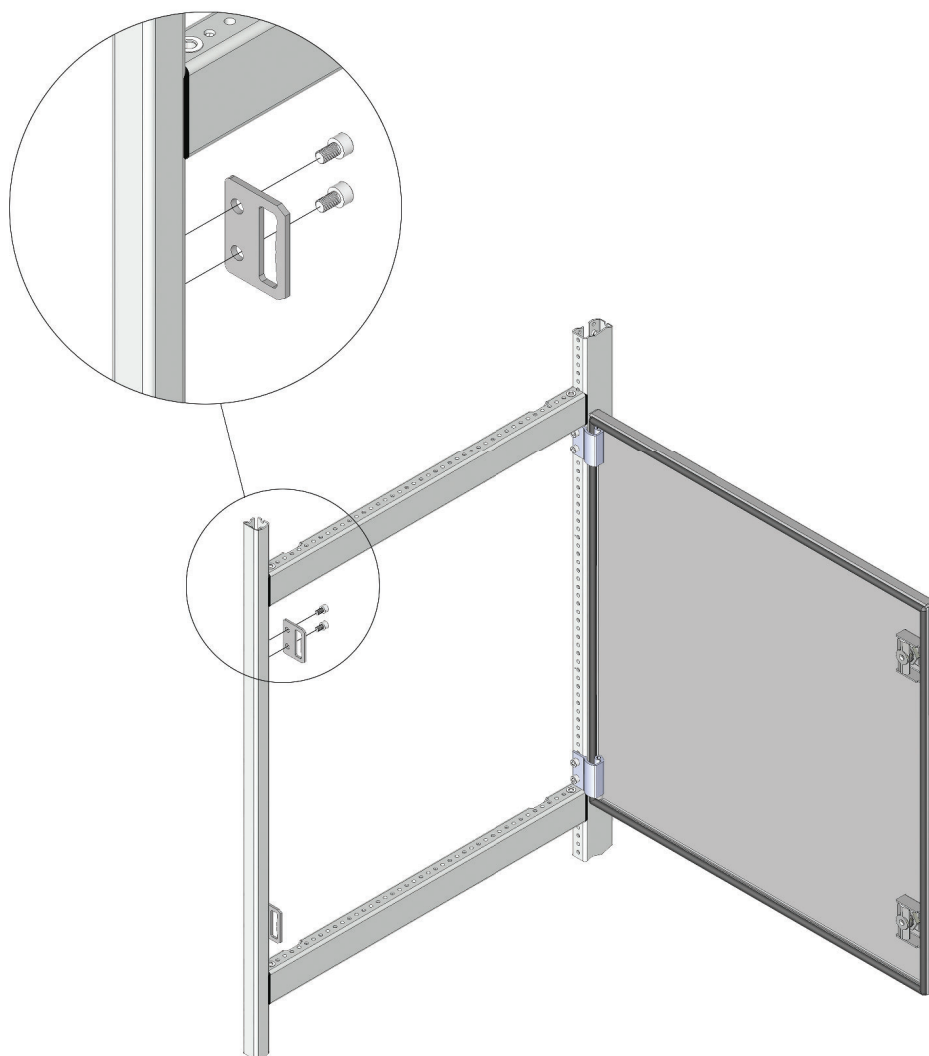

Version 3

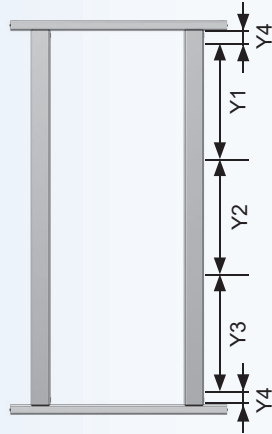

DOOR ■
HINGE POSITION

TYPE	NUMBER OF HINGES	Y ₁	Y ₂	Y ₃	Y ₄
DO 2.2	2	100	-	-	25
DO 2.4	2	300	-	-	25
DO 2.6	2	500	-	-	25
DO 2.8	3	400	300	-	25
DO 2.10	3	500	400	-	25
DO 2.12	3	600	500	-	25
DO 2.14	3	700	600	-	25
DO 2.16	4	500	600	400	25
DO 2.18	4	600	600	500	25
DO 2.20	4	700	600	600	25
DO 2.22	4	800	600	700	25
DO 4.2	2	100	-	-	25
DO 4.3	2	200	-	-	25
DO 4.4	2	300	-	-	25
DO 4.6	2	500	-	-	25
DO 4.8	3	400	300	-	25
DO 4.10	3	500	400	-	25
DO 4.12	3	600	500	-	25
DO 4.14	3	700	600	-	25
DO 4.16	4	500	600	400	25
DO 4.18	4	600	600	500	25
DO 4.20	4	700	600	600	25
DO 4.22	4	800	600	700	25
DO 6.2	2	100	-	-	25
DO 6.3	2	200	-	-	25
DO 6.4	2	300	-	-	25
DO 6.6	2	500	-	-	25
DO 6.8	3	400	300	-	25
DO 6.10	3	500	400	-	25
DO 6.12	3	600	500	-	25
DO 6.14	3	700	600	-	25
DO 6.16	4	500	600	400	25
DO 6.18	4	600	600	500	25
DO 6.20	4	700	600	600	25
DO 6.22	4	800	600	700	25
DO 8.4	2	300	-	-	25
DO 8.6	2	500	-	-	25
DO 8.8	3	400	300	-	25
DO 8.10	3	500	400	-	25
DO 8.12	3	600	500	-	25
DO 8.14	3	700	600	-	25
DO 8.16	4	500	600	400	25
DO 8.18	4	600	600	500	25
DO 8.20	4	700	600	600	25
DO 8.22	4	800	600	700	25
DO 10.10	3	500	400	-	25
DO 10.12	3	600	500	-	25
DO 10.14	3	700	600	-	25
DO 10.16	4	500	600	400	25
DO 10.18	4	600	600	600	25
DO 10.20	4	700	600	600	25
DO 10.22	4	800	600	700	25
DO 12.10	3	500	400	-	25
DO 12.12	3	600	500	-	25
DO 12.14	3	700	600	-	25
DO 12.16	4	500	600	400	25
DO 12.18	4	600	600	500	25
DO 12.20	4	700	600	600	25
DO 12.22	4	800	600	700	25

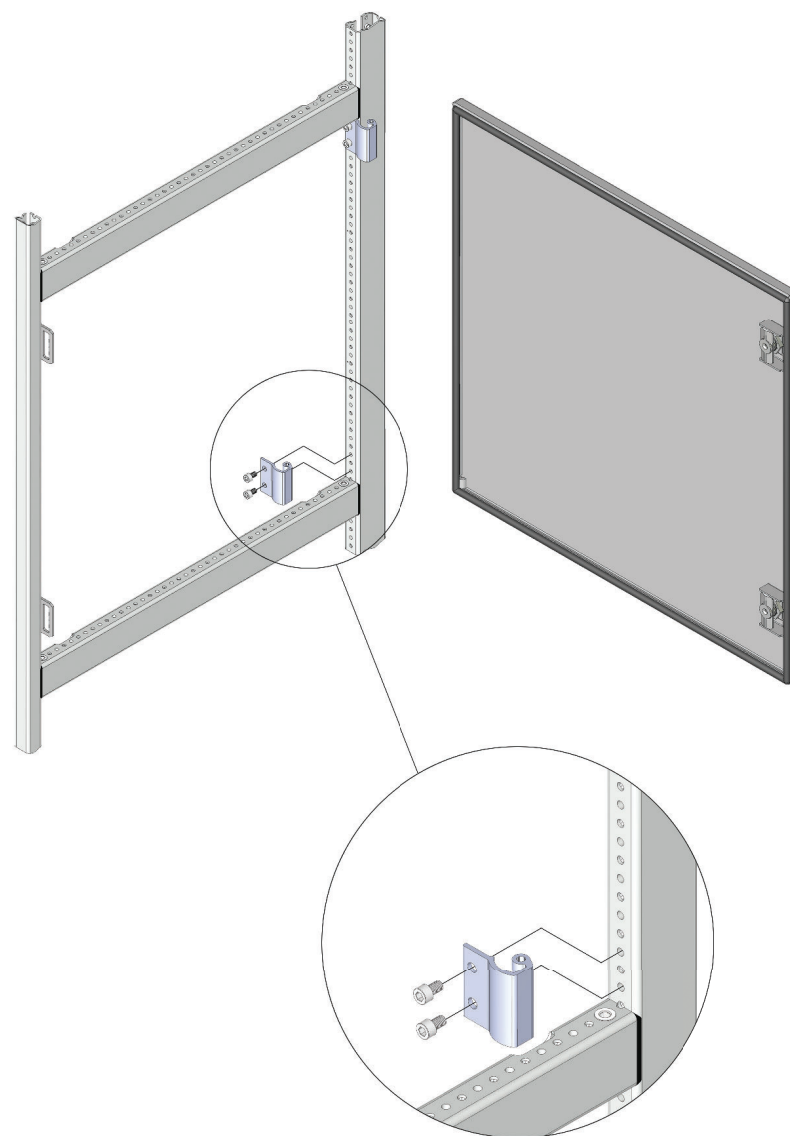

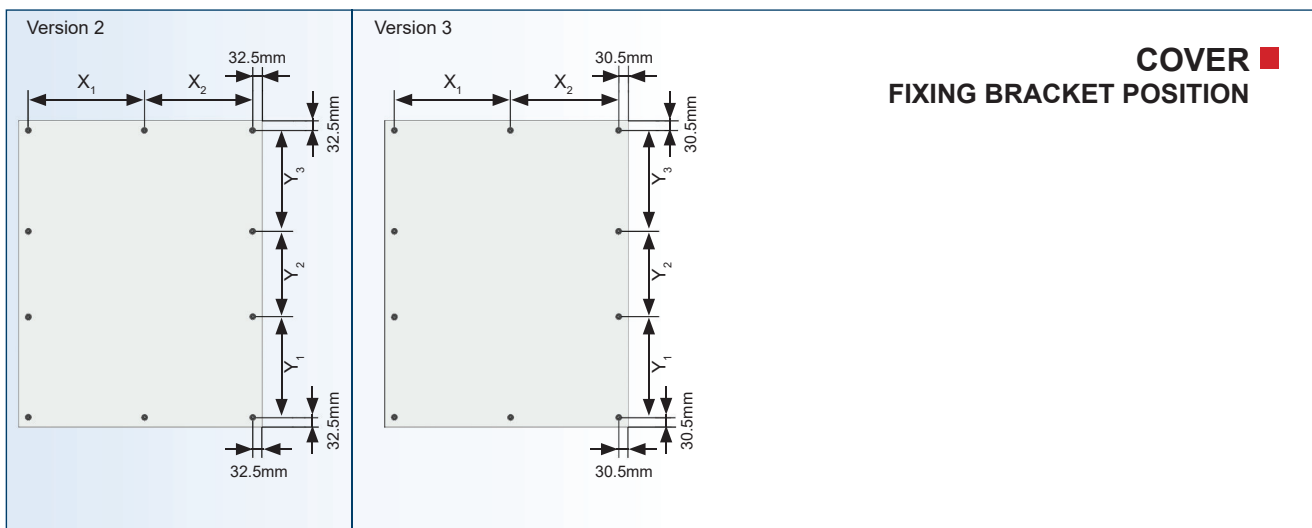

COVER ■
FIXING BRACKET POSITION

TYPE	NO. OF SCREWS (X)	X ₁	X ₂	NO. OF SCREWS (Y)	Y ₁	Y ₂	Y ₃
COV 2.2	2	125	-	2	125	-	-
COV 2.4	2	125	-	2	325	-	-
COV 2.6	2	125	-	2	525	-	-
COV 2.8	2	125	-	3	375	350	-
COV 2.10	2	125	-	4	325	275	325
COV 2.12	2	125	-	4	400	325	400
COV 2.14	2	125	-	4	450	425	450
COV 2.16	2	125	-	4	500	525	500
COV 2.18	2	125	-	4	525	675	525
COV 2.20	2	125	-	4	600	725	600
COV 2.22	2	125	-	4	700	725	700
COV 4.3	2	325	-	2	225	-	-
COV 4.4	2	325	-	2	325	-	-
COV 4.6	2	325	-	2	525	-	-
COV 4.8	2	325	-	3	375	350	-
COV 4.10	2	325	-	4	325	275	325
COV 4.12	2	325	-	4	400	325	400
COV 4.14	2	325	-	4	450	425	450
COV 4.16	2	325	-	4	500	525	500
COV 4.18	2	325	-	4	525	675	525
COV 4.20	2	325	-	4	600	725	600
COV 4.22	2	325	-	4	700	725	700
COV 6.3	2	525	-	2	225	-	-
COV 6.6	2	525	-	2	525	-	-
COV 6.8	2	525	-	3	375	350	-
COV 6.10	2	525	-	4	325	275	325
COV 6.12	2	525	-	4	400	325	400
COV 6.14	2	525	-	4	450	425	450
COV 6.16	2	525	-	4	500	525	500
COV 6.18	2	525	-	4	525	675	525
COV 6.20	2	525	-	4	600	725	600
COV 6.22	2	525	-	4	700	725	700
COV 8.8	3	375	350	3	375	350	-
COV 8.10	3	375	350	4	325	275	325
COV 8.12	3	375	350	4	400	325	400
COV 8.14	3	375	350	4	450	425	450
COV 8.16	3	375	350	4	500	525	500
COV 8.18	3	375	350	4	525	675	525
COV 8.20	3	375	350	4	600	725	600
COV 8.22	3	375	350	4	700	725	700

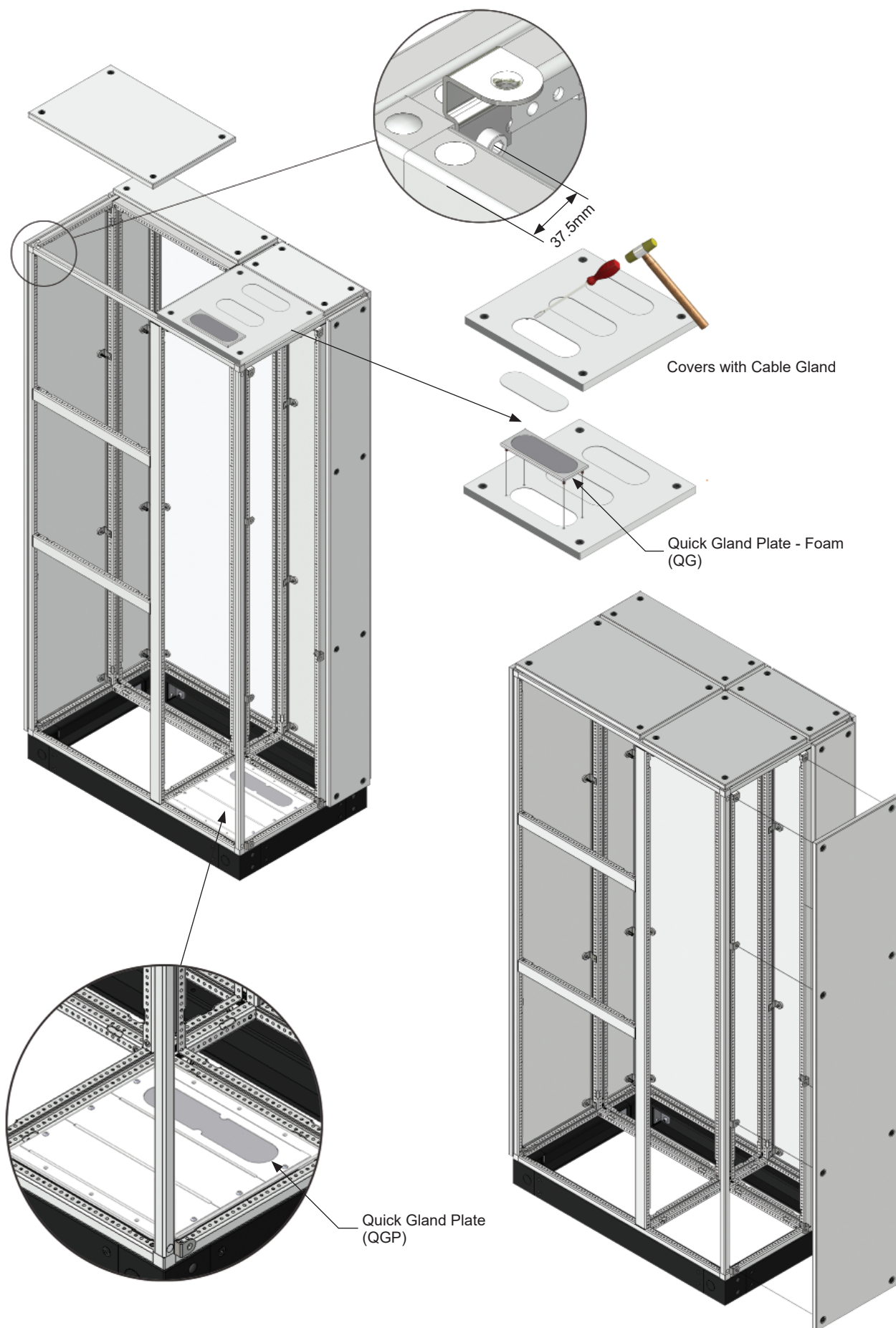

* Please see the Constructors Manual online at www.elsteel.com for more details on Gland Plates.

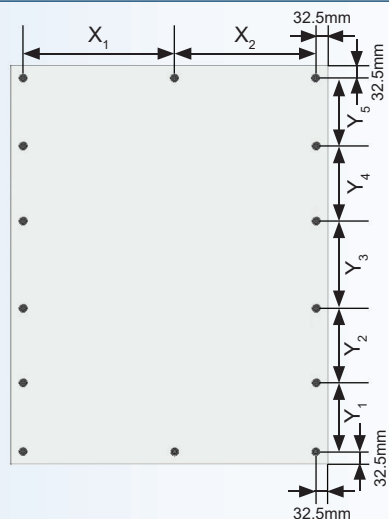

FLAT COVER ■
FIXING BRACKET POSITION

SIZE (W×H)	NO. OF SCREWS (X)	X ₁	X ₂	NO. OF SCREWS (Y)	Y ₁	Y ₂	Y ₃	Y ₄	Y ₅
200 × 200	2	125	-	2	125	-	-	-	-
200 × 400	2	125	-	2	325	-	-	-	-
200 × 600	2	125	-	3	275	250	-	-	-
200 × 800	2	125	-	3	375	350	-	-	-
200 × 1000	2	125	-	4	325	275	325	-	-
200 × 1200	2	125	-	4	400	325	400	-	-
200 × 1400	2	125	-	6	325	275	125	275	325
200 × 1600	2	125	-	6	325	275	325	275	325
200 × 1800	2	125	-	6	400	325	275	325	400
200 × 2000	2	125	-	6	400	400	325	400	400
200 × 2200	2	125	-	6	425	425	425	425	425
400 × 400	2	325	-	2	325	-	-	-	-
400 × 600	2	325	-	3	275	250	-	-	-
400 × 800	2	325	-	3	375	350	-	-	-
400 × 1000	2	325	-	4	325	275	325	-	-
400 × 1200	2	325	-	4	400	325	400	-	-
400 × 1400	2	325	-	6	325	275	125	275	325
400 × 1600	2	325	-	6	325	275	325	275	325
400 × 1800	2	325	-	6	400	325	275	325	400
400 × 2000	2	325	-	6	400	400	325	400	400
400 × 2200	2	325	-	6	425	425	425	425	425
600 × 600	2	525	-	3	275	250	-	-	-
600 × 800	2	525	-	3	375	350	-	-	-
600 × 1000	2	525	-	4	325	275	325	-	-
600 × 1200	2	525	-	4	400	325	400	-	-
600 × 1400	2	525	-	6	325	275	125	275	325
600 × 1600	2	525	-	6	325	275	325	275	325
600 × 1800	2	525	-	6	400	325	275	325	400
600 × 2000	2	525	-	6	400	400	325	400	400
600 × 2200	2	525	-	6	425	425	425	425	425
800 × 800	3	375	350	3	375	350	-	-	-
800 × 1000	3	375	350	4	325	275	325	-	-
800 × 1200	3	375	350	4	400	325	400	-	-
800 × 1400	3	375	350	6	325	275	125	275	325
800 × 1600	3	375	350	6	325	275	325	275	325
800 × 1800	3	375	350	6	400	325	275	325	400
800 × 2000	3	375	350	6	400	400	325	400	400
800 × 2200	3	375	350	6	425	425	425	425	425

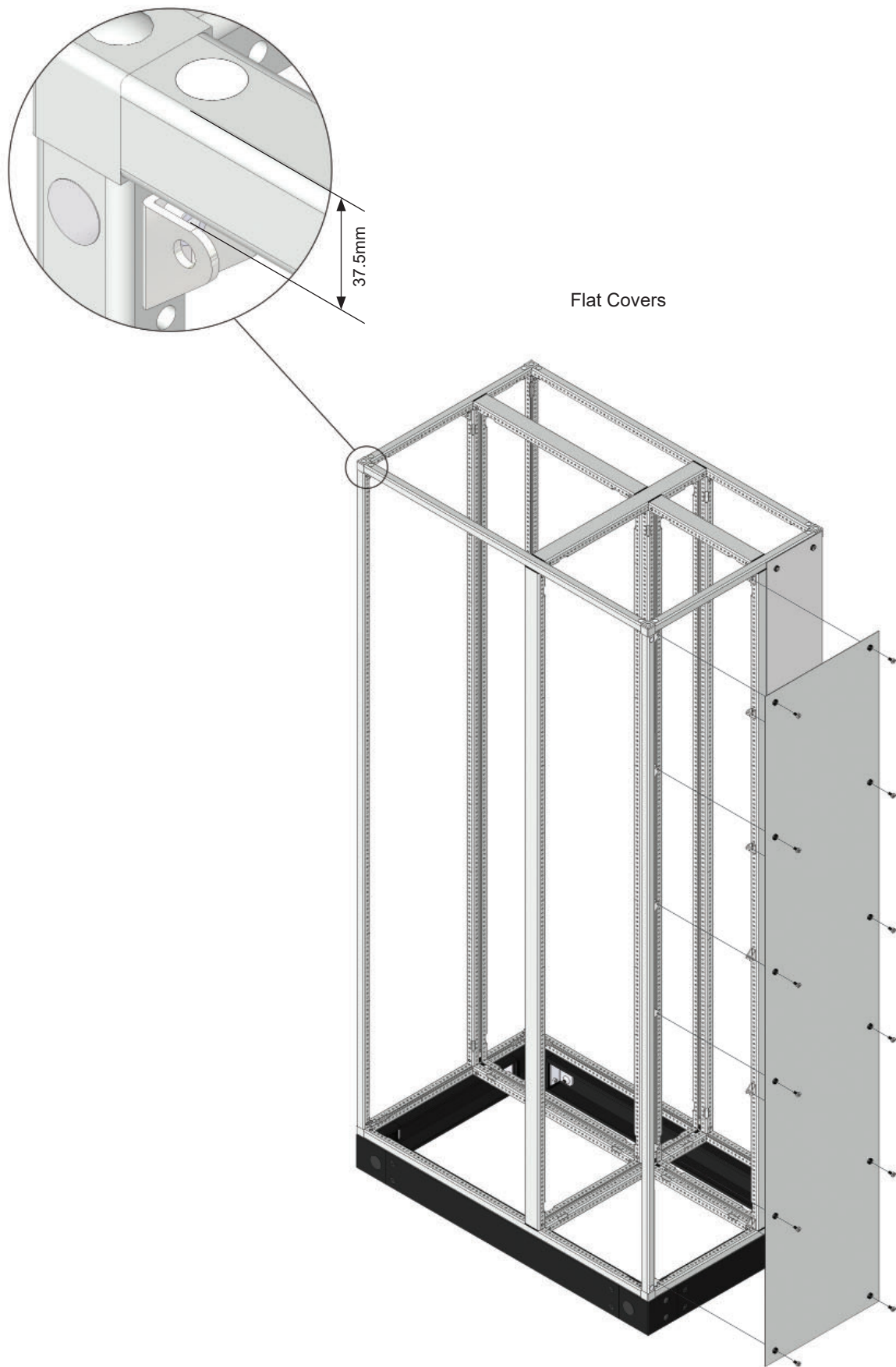

LIFTING AND MOVING THE PANEL BOARD SECTION

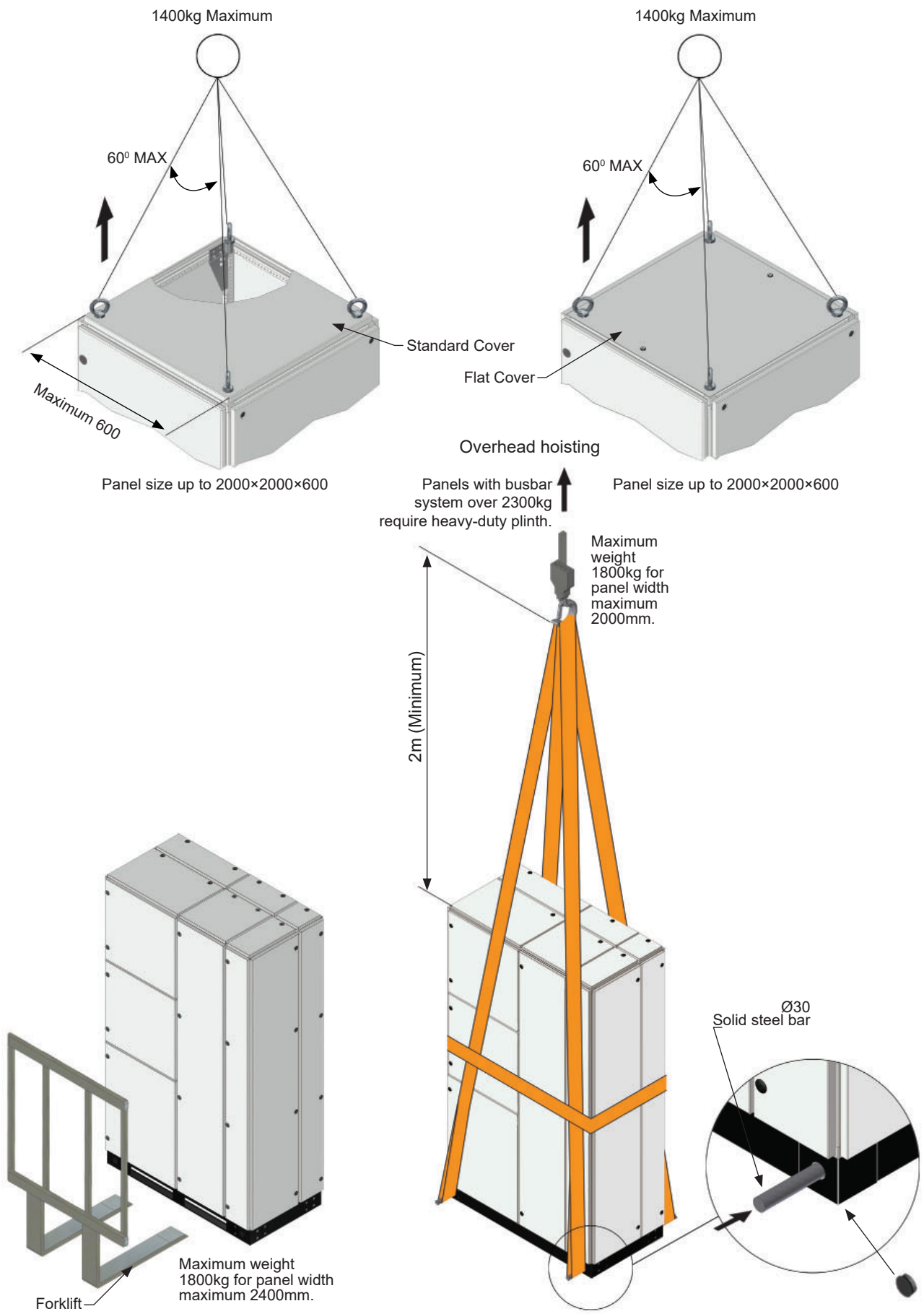

JOINING TWO PANELS

Panels must be on an even surface.

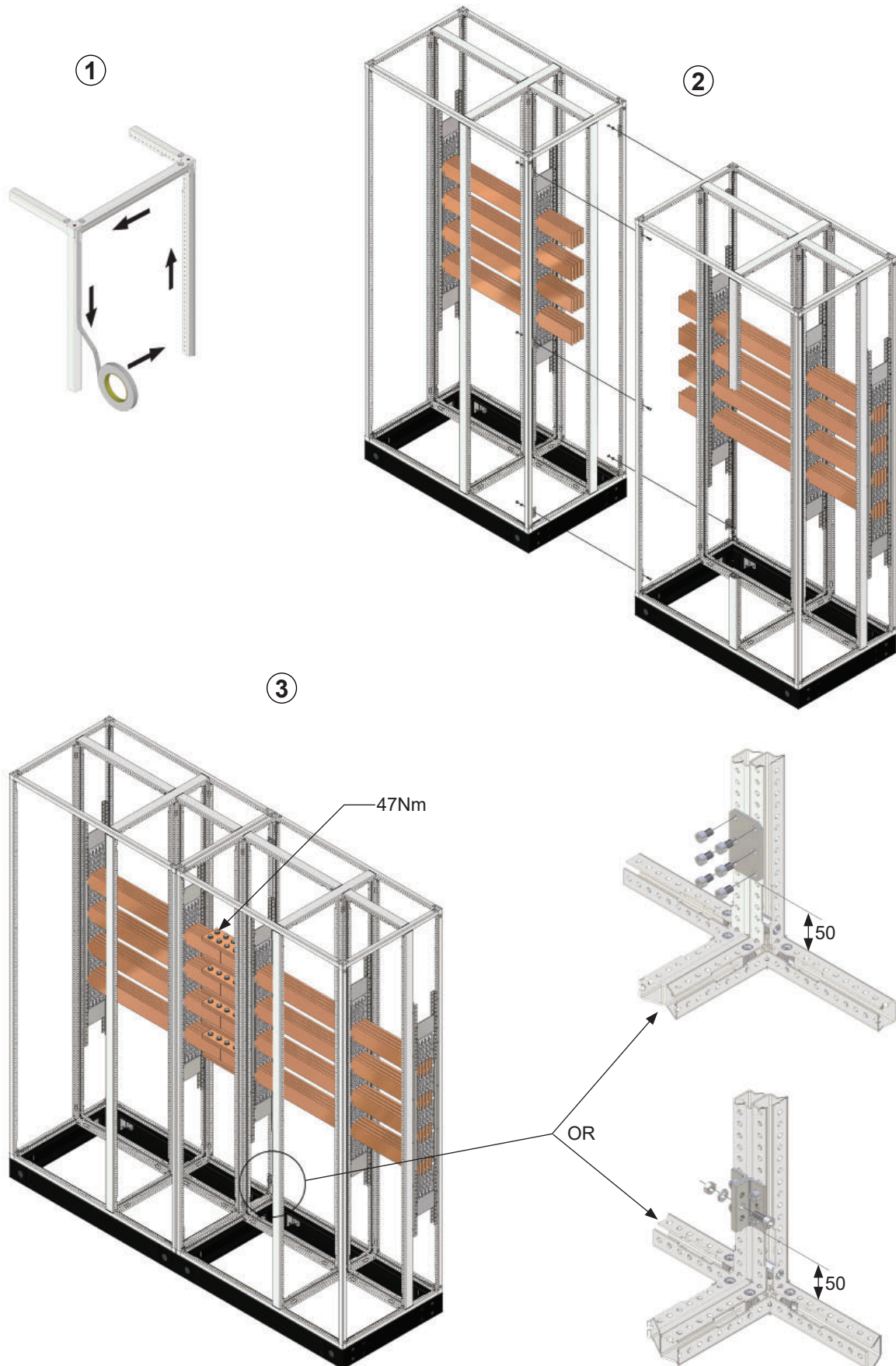

SECURING THE PANEL BOARD TO THE FLOOR

Panels must be on an even surface.

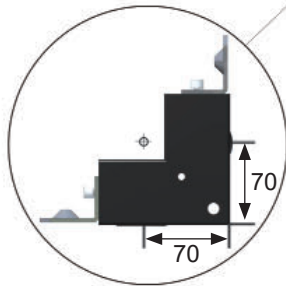
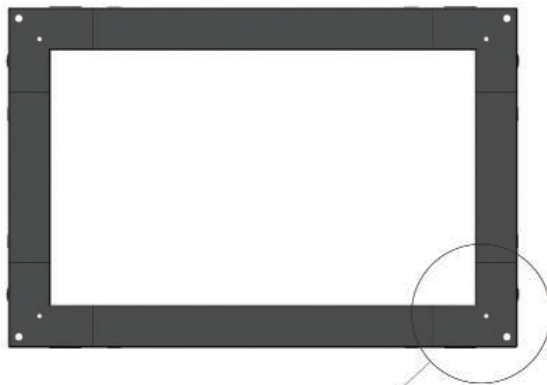

Detail for drilling

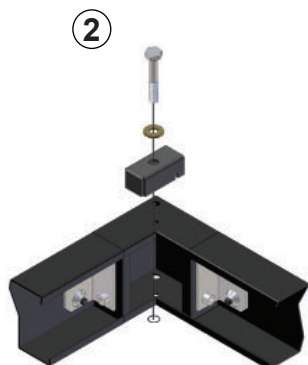
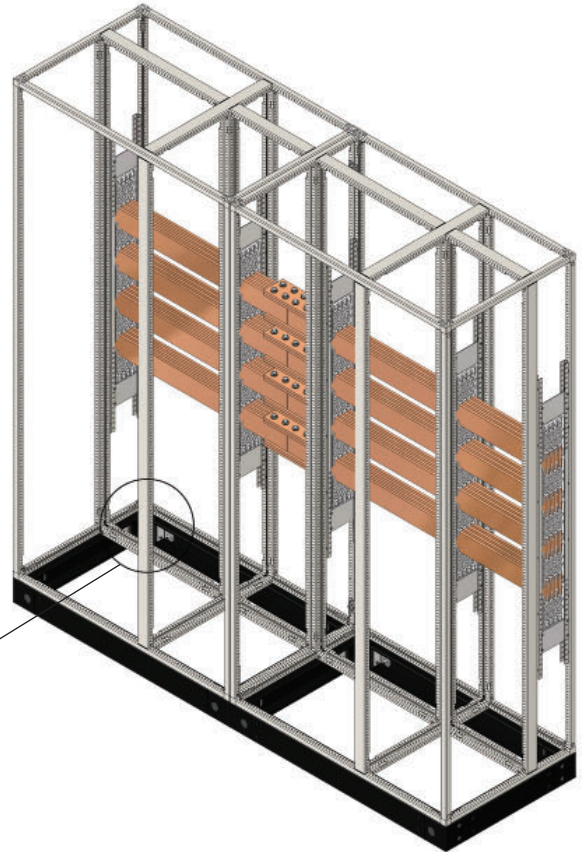

Ensure all screws, joints, bolts etc. are tightened properly before installation.

Bolt Size	Torque Nm
M5	6
M6	10
M8	24
M10	47
M12	81

CLAMPING ANGLE FOR OUTSIDE PLINTH

SECURING THE PANEL BOARD TO THE FLOOR

Panels must be on an even surface.

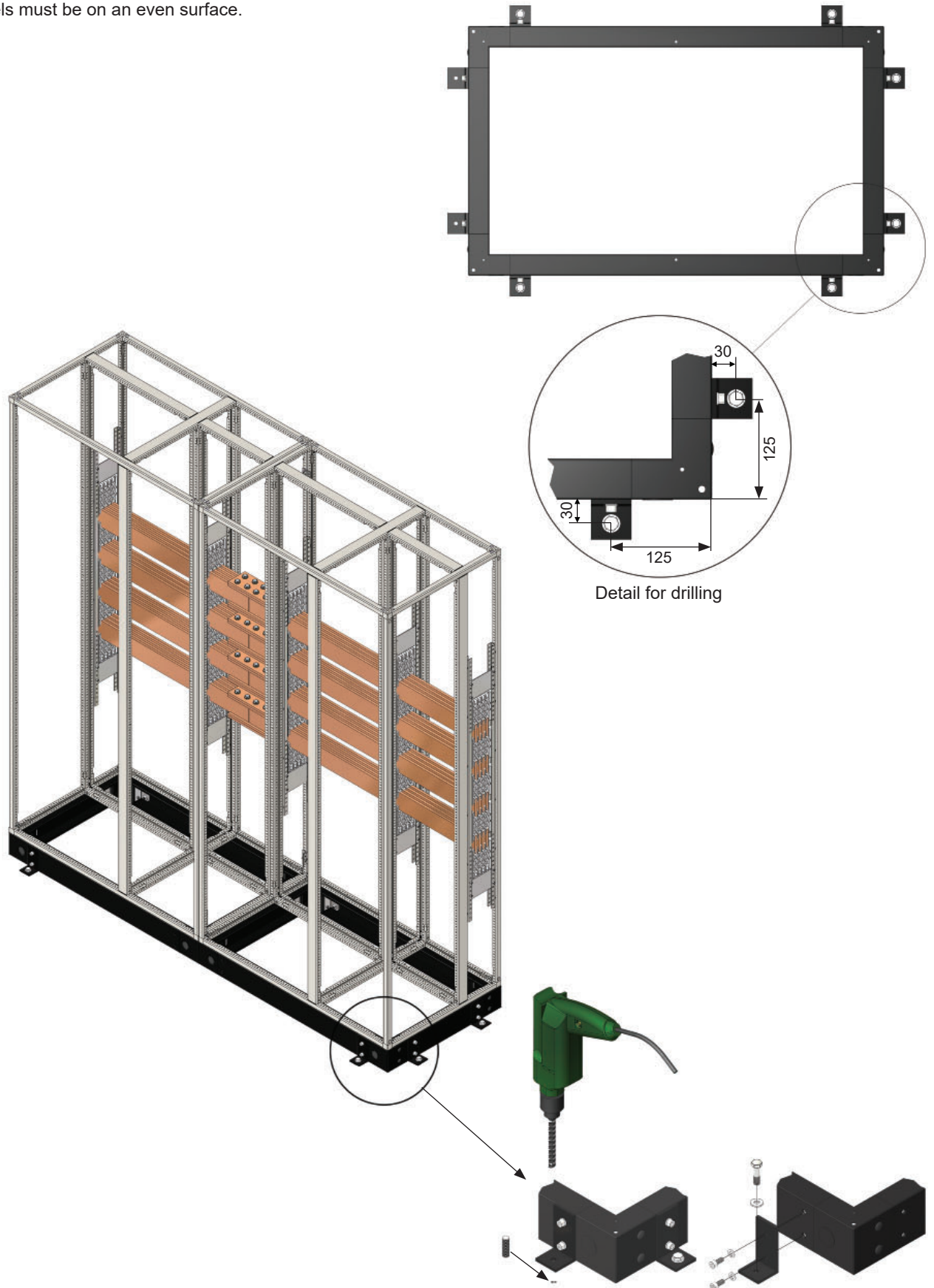

MAIN BUSBAR ARRANGEMENT EXAMPLE

TECHNICAL PROPERTIES

Main Busbar location	- Top
Type of main busbar holder	- BH/ OMH
Cable entry direction	- Bottom

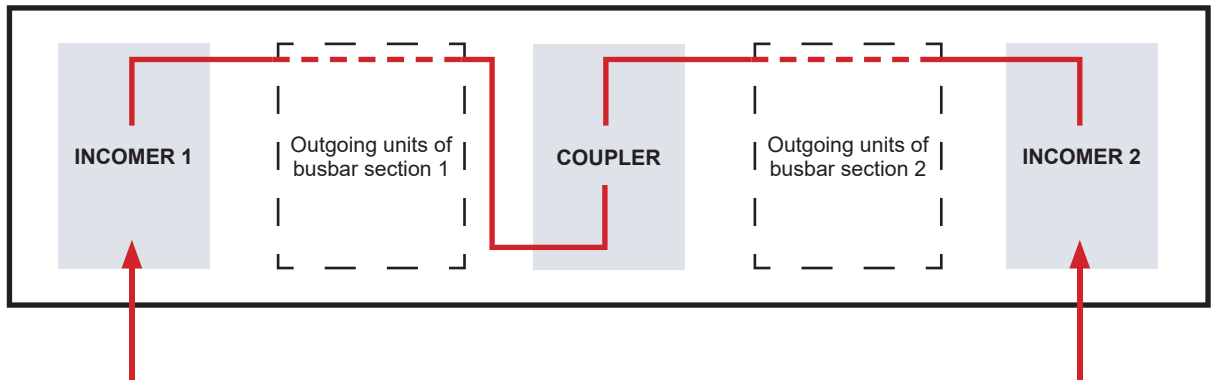

Techno Module panel configuration

Incomer 1

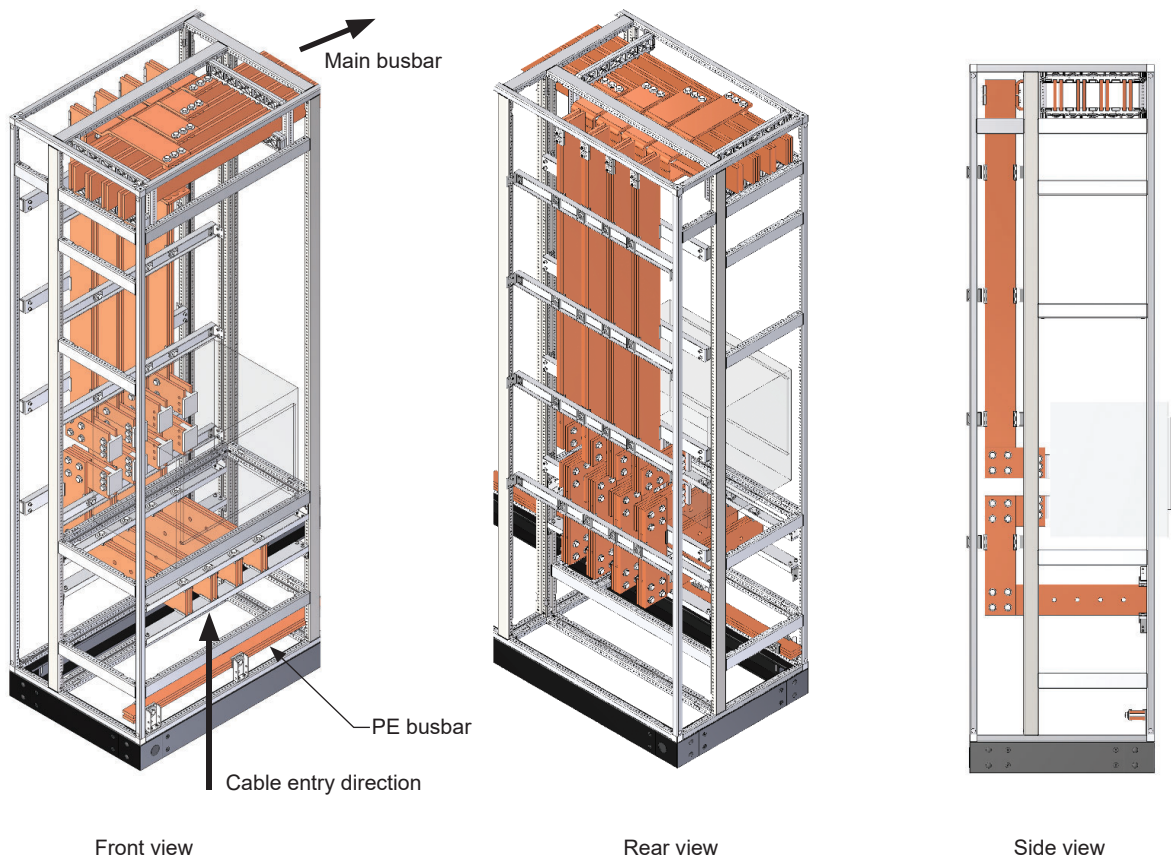

* Separation plates, Doors, Covers are not shown

Coupler

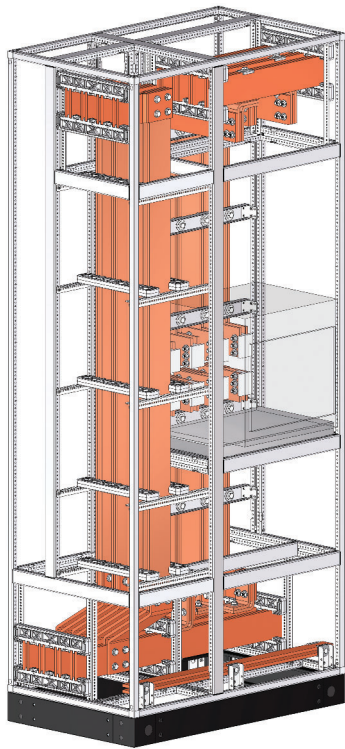

Front view

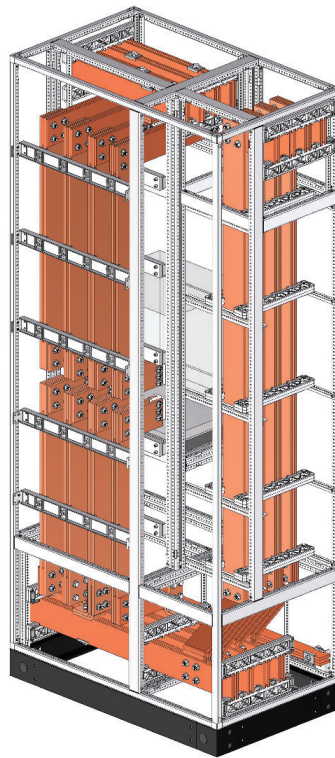

Rear view

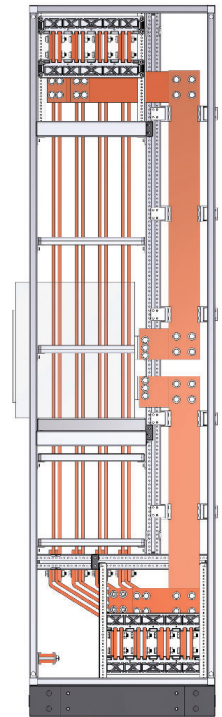

Side view

Incomer 2

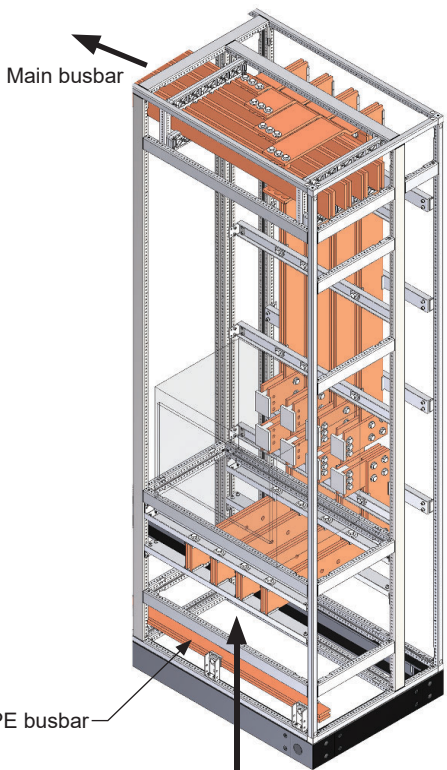

Front view

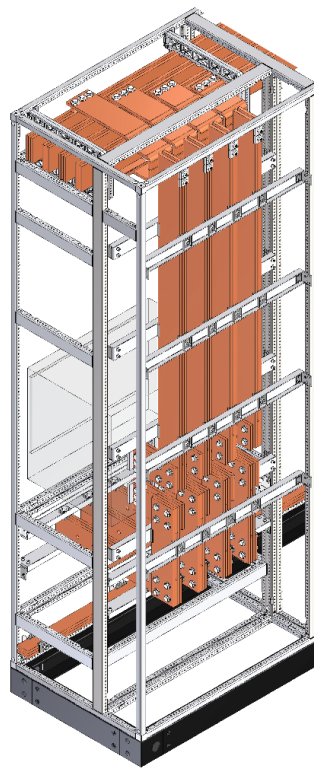

Rear view

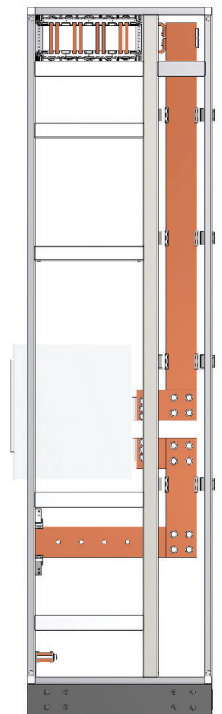

Side view

* Separation plates, Doors, Covers are not shown

MAIN BUSBAR ARRANGEMENT EXAMPLE

TECHNICAL PROPERTIES

Main Busbar location	- Bottom
Type of main busbar holder	- BH/ OMH
Cable entry direction	- Top

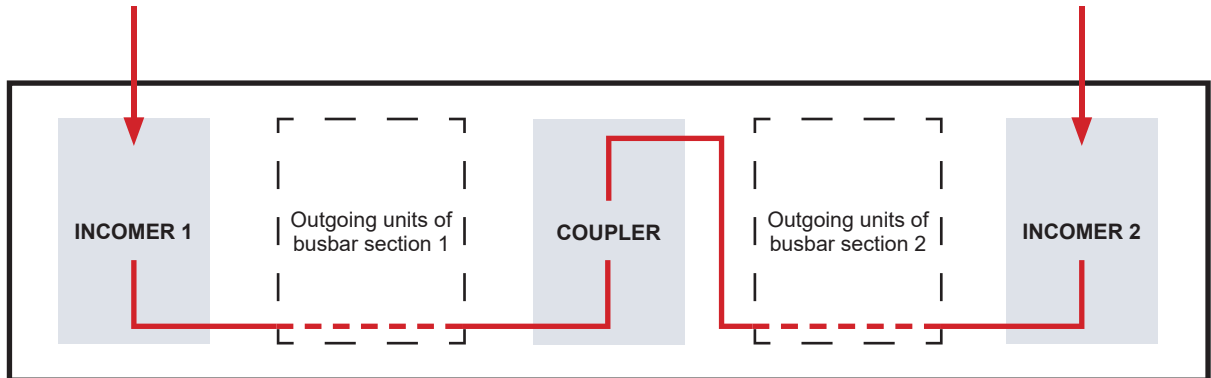

Techno Module panel configuration

Incomer 1

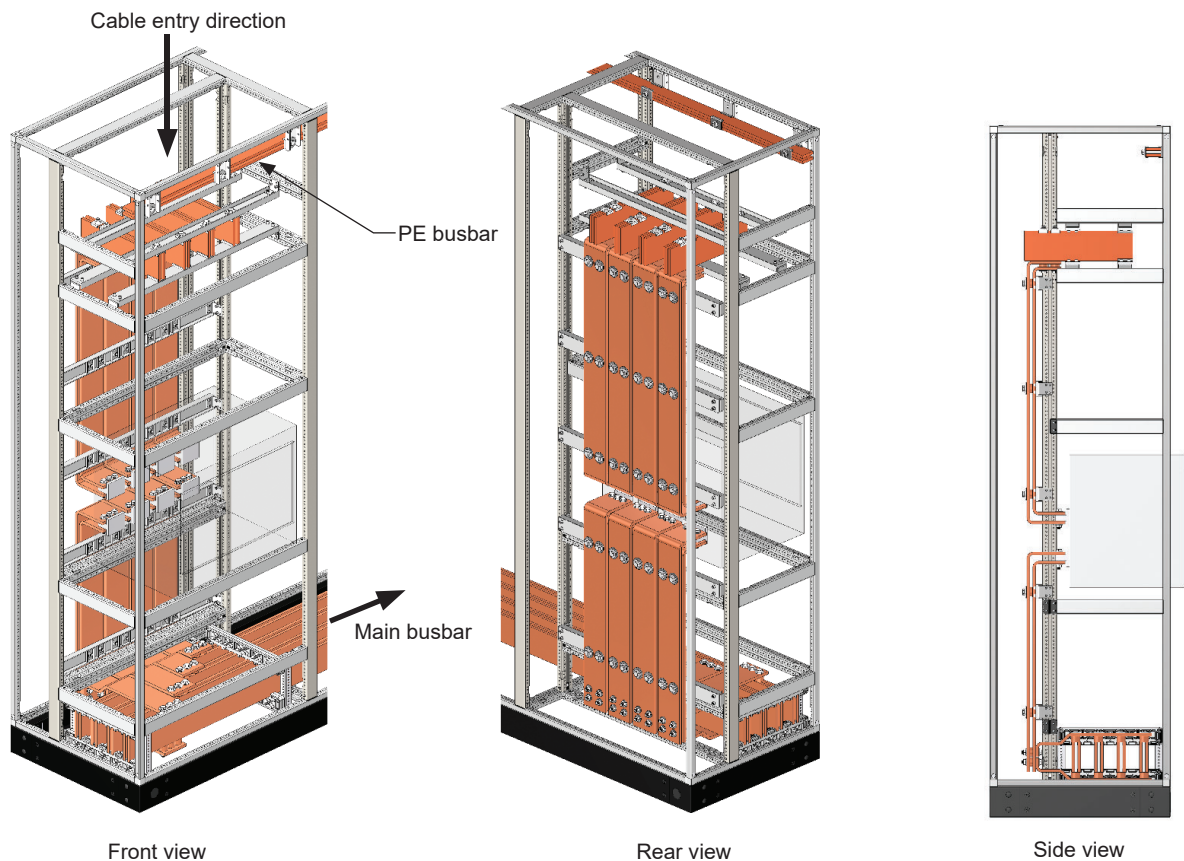

* Separation plates, Doors, Covers are not shown

Coupler

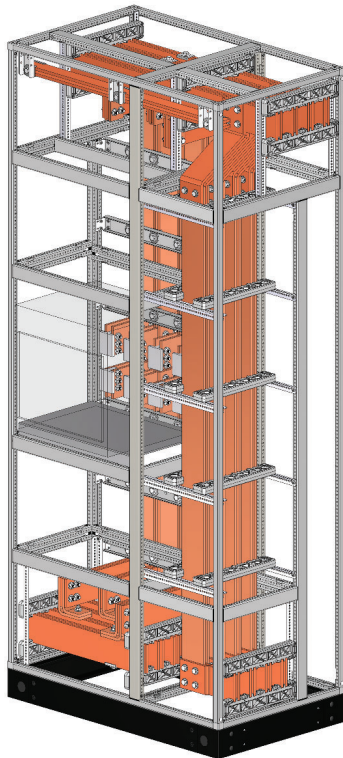

Front view

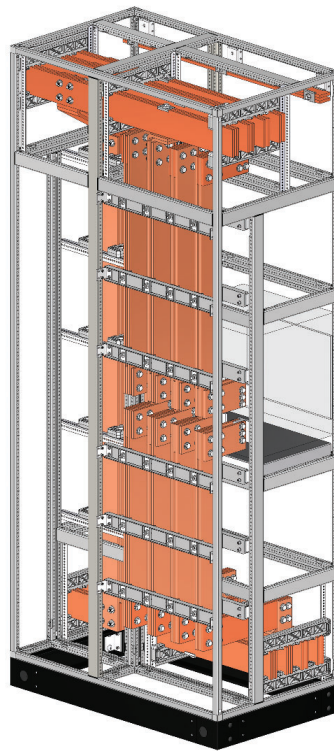

Rear view

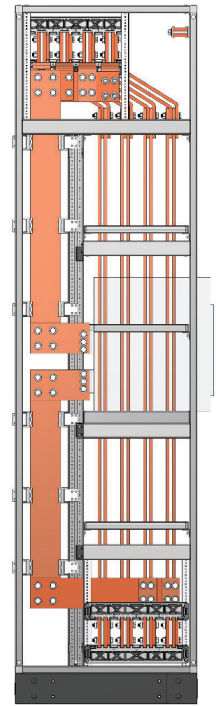

Side view

Incomer 2

Cable entry direction

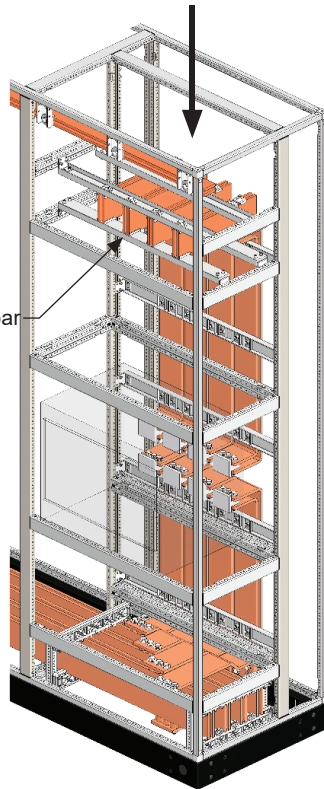

PE busbar

Main busbar

Front view

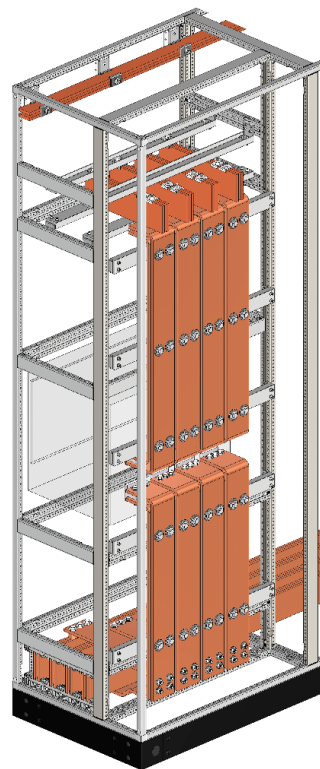

Rear view

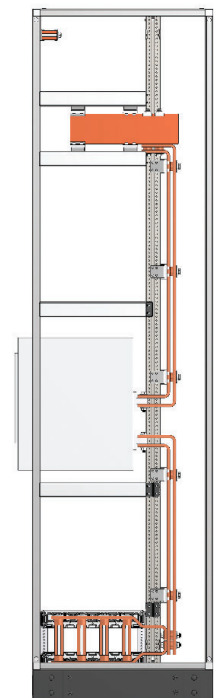

Side view

* Separation plates, Doors, Covers are not shown

MAIN BUSBAR ARRANGEMENT EXAMPLE

TECHNICAL PROPERTIES

Main Busbar location	- Rear
Type of main busbar holder	- MAB/ BH
Cable entry direction	- Bottom

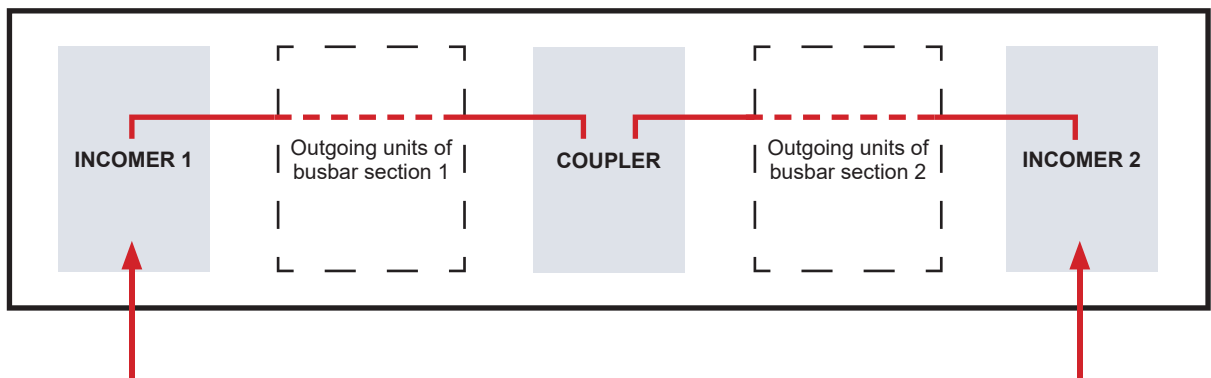

Techno Module panel configuration

Incomer 1

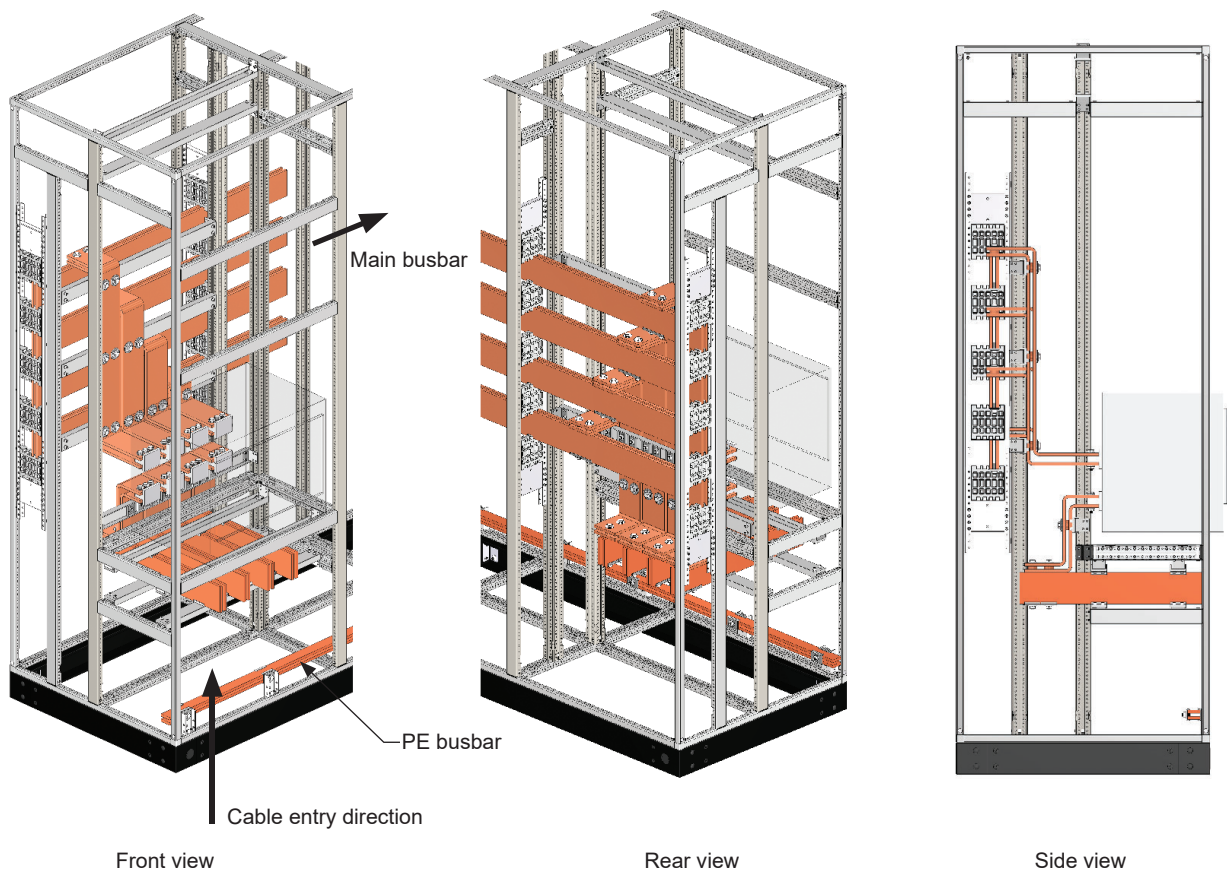

* Separation plates, Doors, Covers are not shown

Coupler

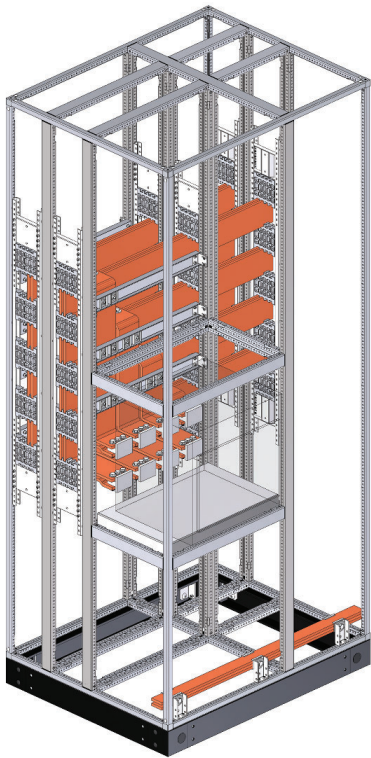

Front view

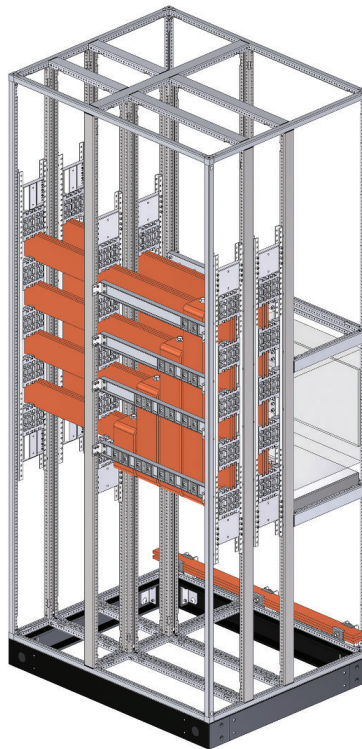

Rear view

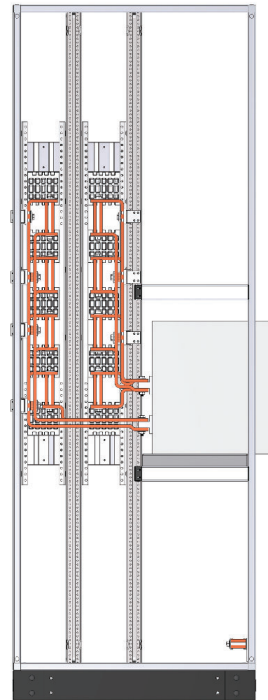

Side view

Incomer 2

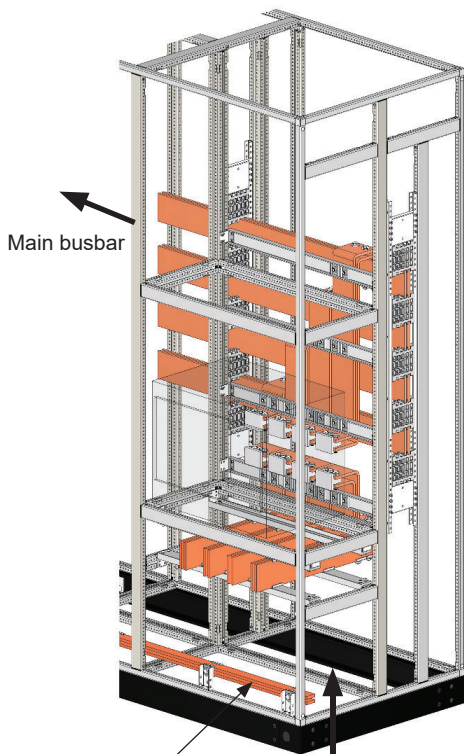

Front view

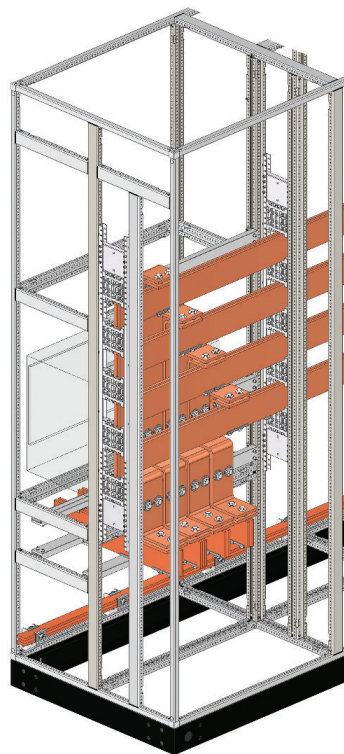

Rear view

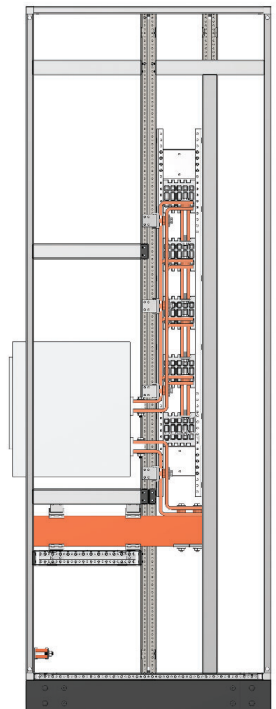

Side view

* Separation plates, Doors, Covers are not shown

MAIN BUSBAR ARRANGEMENT EXAMPLE

TECHNICAL PROPERTIES

Main Busbar location	- Rear
Type of main busbar holder	- MAB/ BH
Cable entry direction	- Top

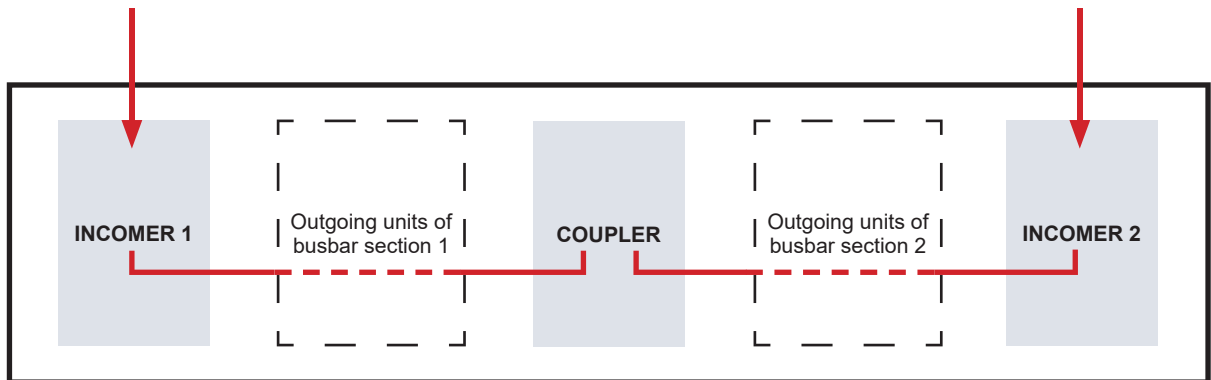

Techno Module panel configuration

Incomer 1

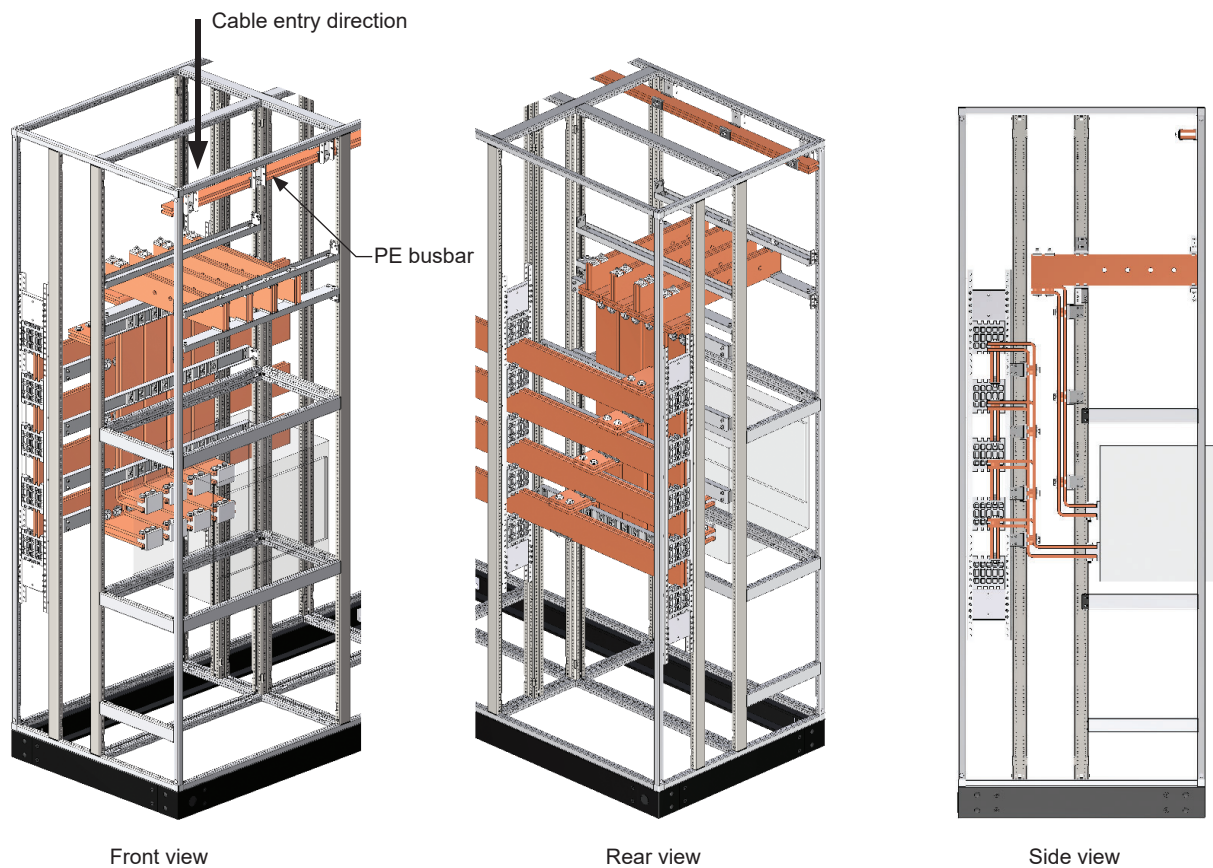

* Separation plates, Doors, Covers are not shown

Coupler

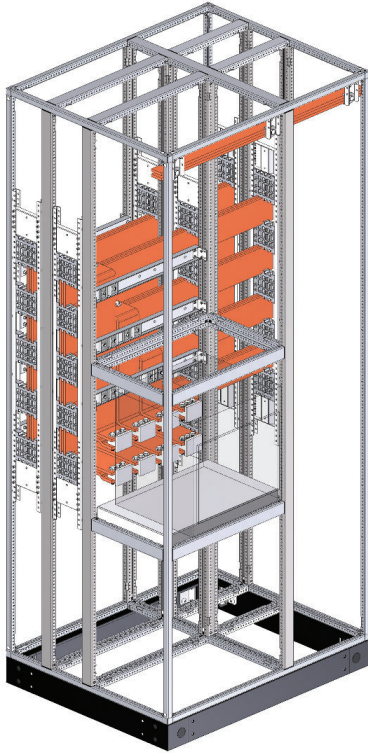

Front view

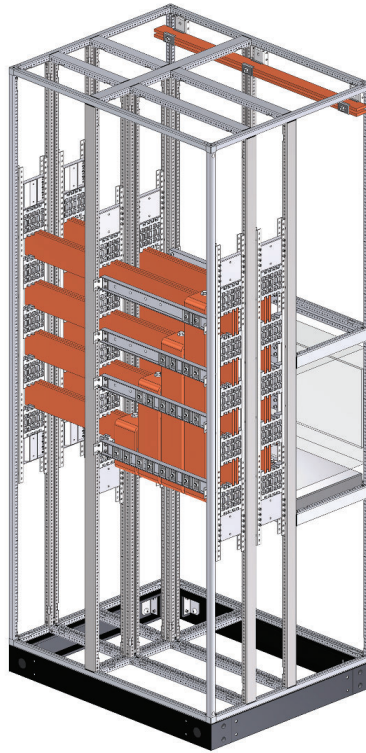

Rear view

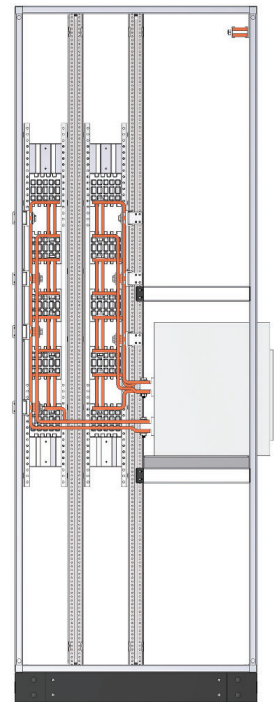

Side view

Incomer 2

Cable entry direction

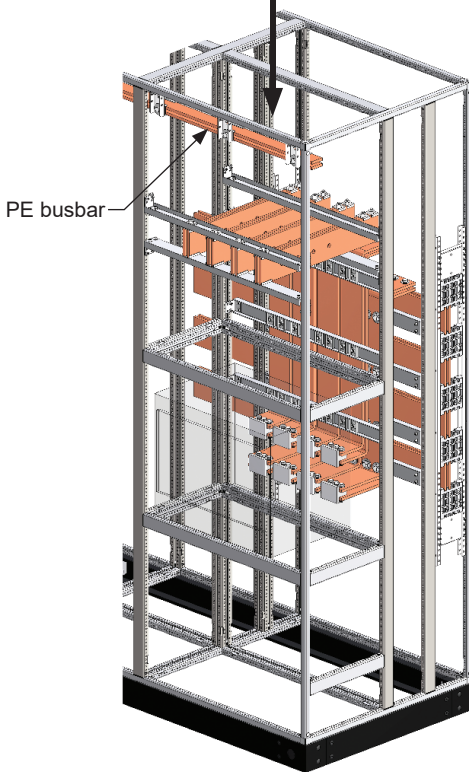

Front view

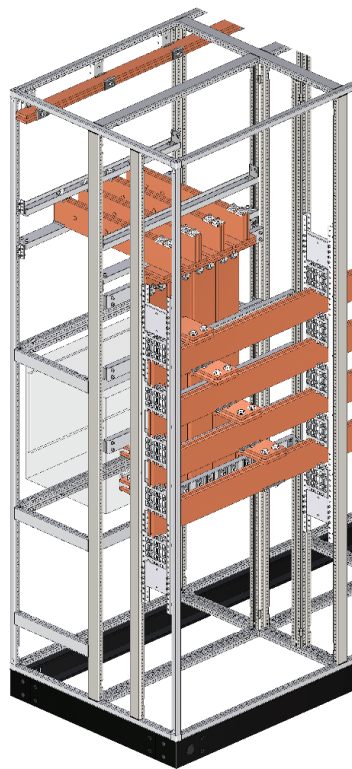

Rear view

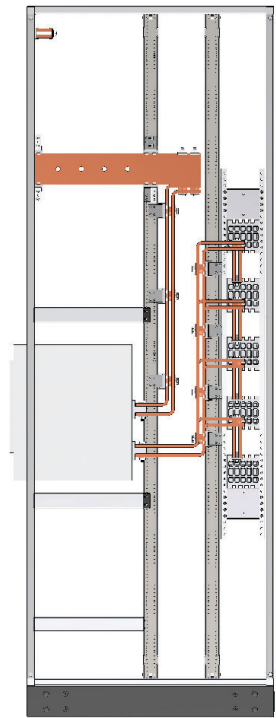

Side view

* Separation plates, Doors, Covers are not shown

MAIN BUSBAR ARRANGEMENT EXAMPLE

TECHNICAL PROPERTIES

Main Busbar location	- Rear
Type of main busbar holder	- MAB/ BH
Cable entry direction	- Bottom

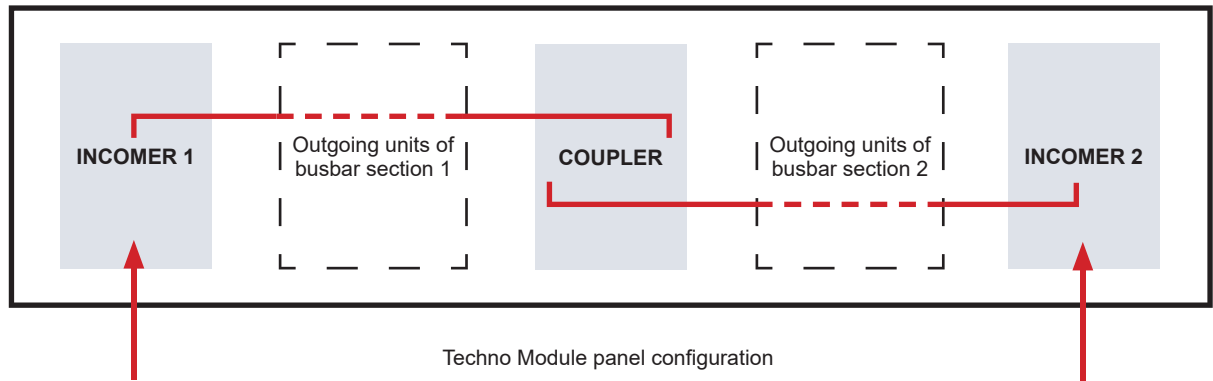

Incomer 1

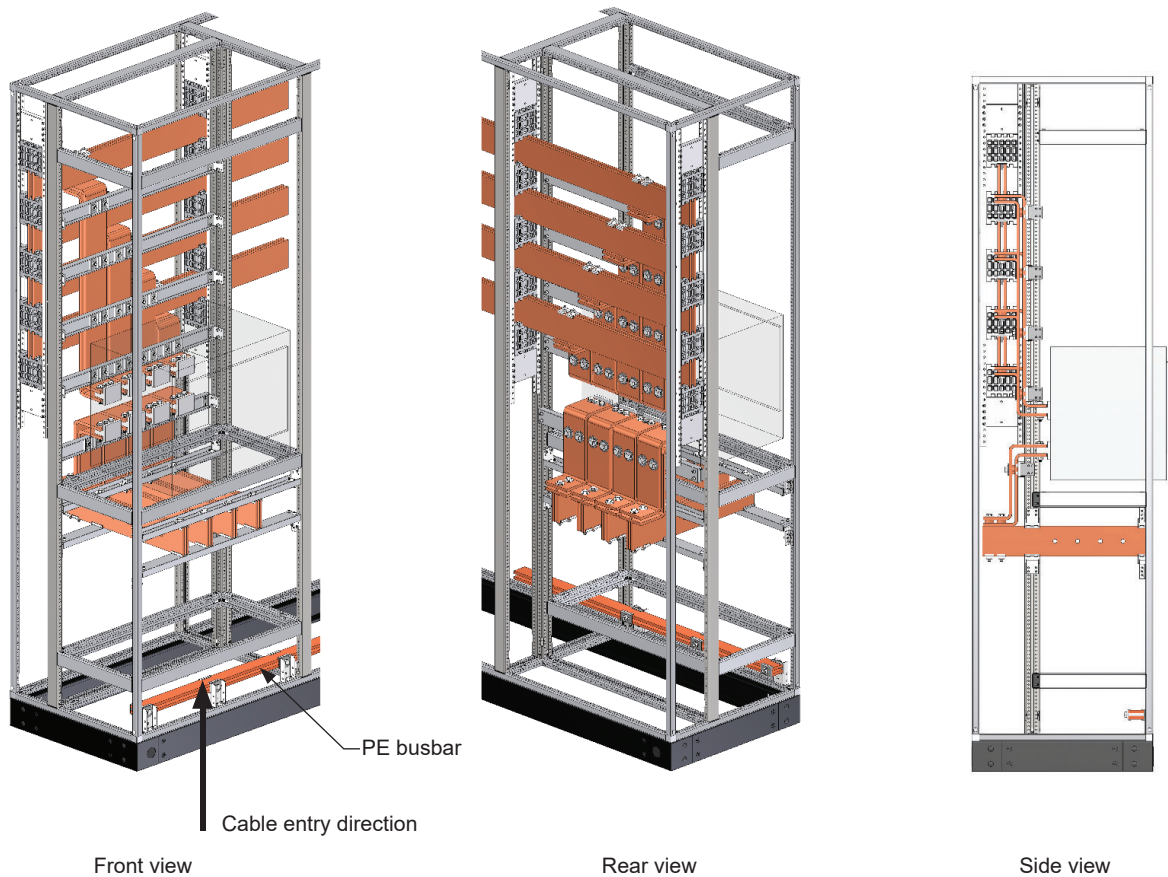

* Separation plates, Doors, Covers are not shown

Coupler

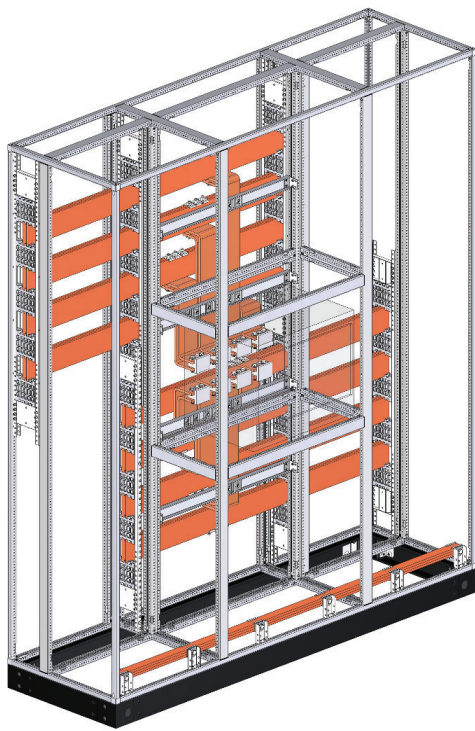

Front view

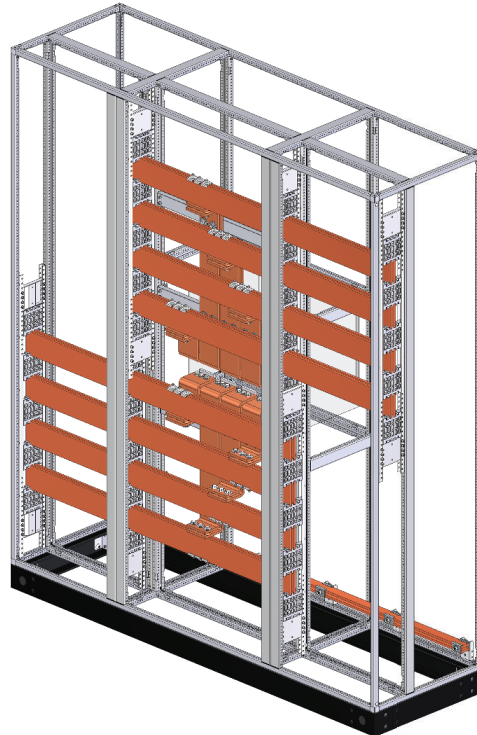

Rear view

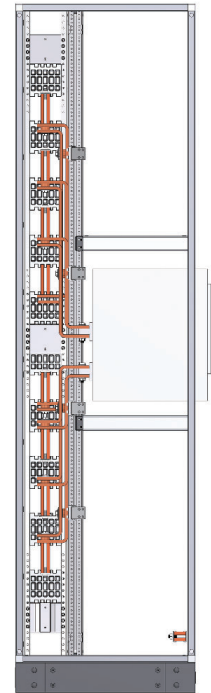

Side view

Incomer 2

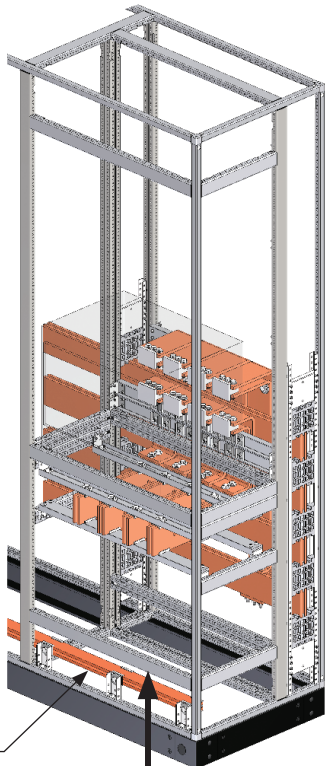

PE busbar

Cable entry direction

Front view

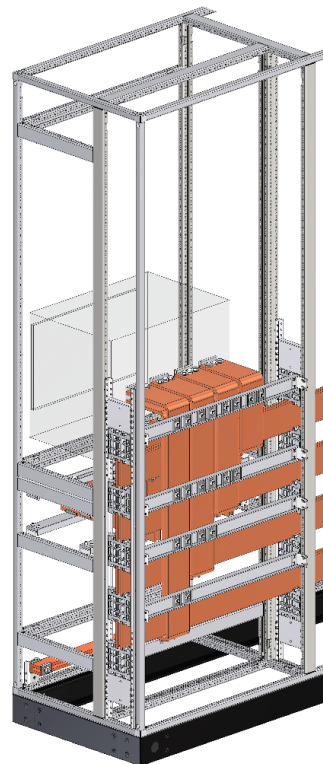

Rear view

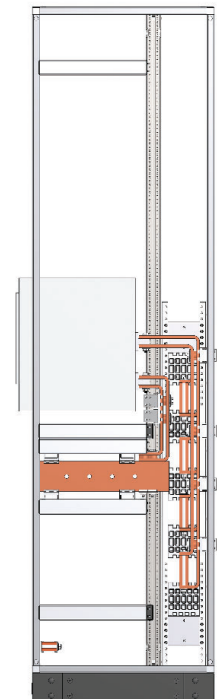

Side view

* Separation plates, Doors, Covers are not shown

MAIN BUSBAR ARRANGEMENT EXAMPLE

TECHNICAL PROPERTIES

Main Busbar location	- Rear
Type of main busbar holder	- MAB/ BH
Cable entry direction	- Top

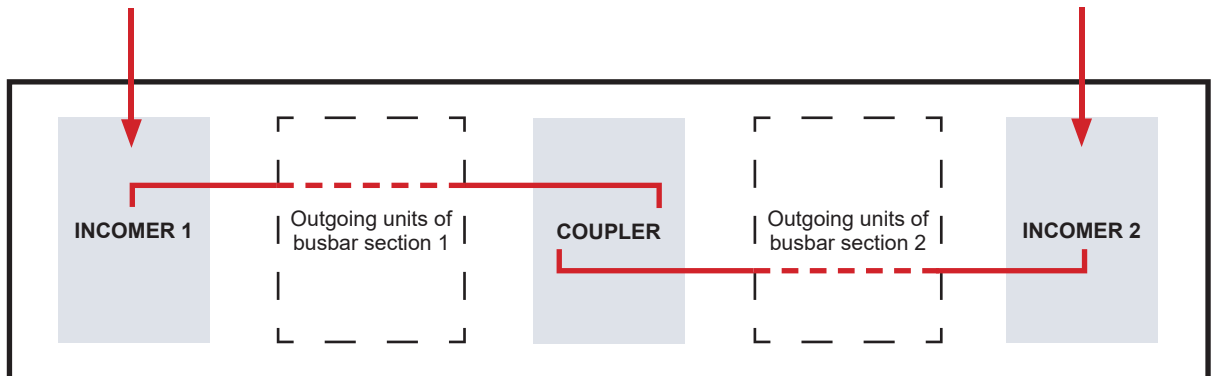

Techno Module panel configuration

Incomer 1

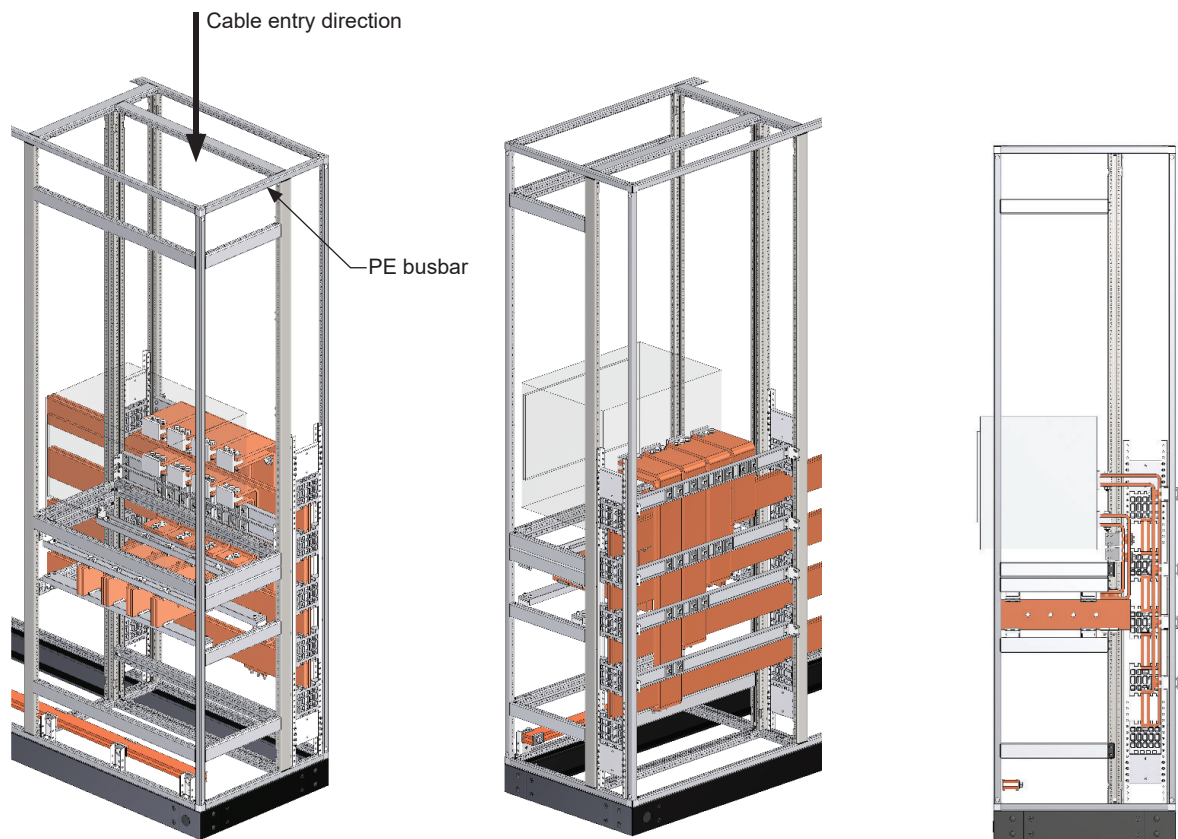

Front view

Rear view

Side view

* Separation plates, Doors, Covers are not shown

Coupler

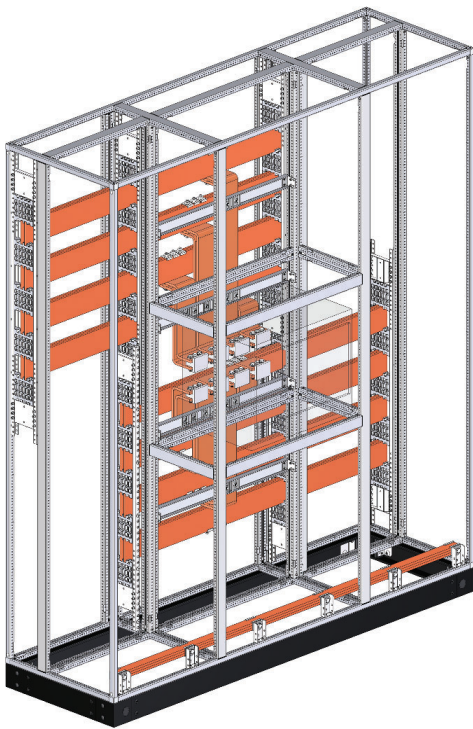

Front view

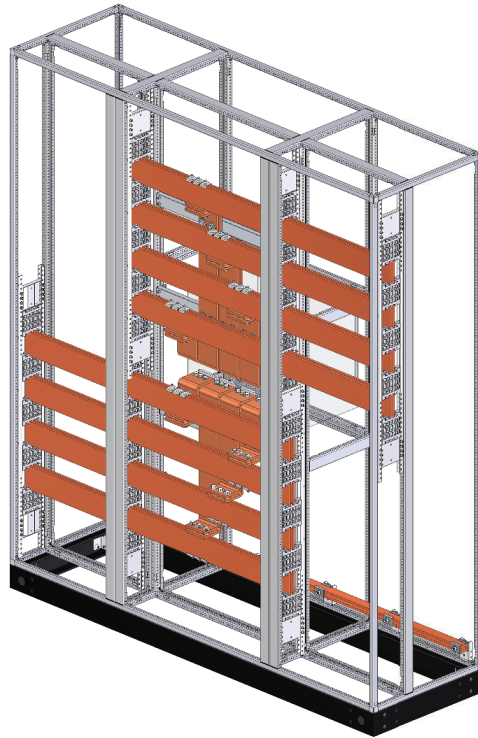

Rear view

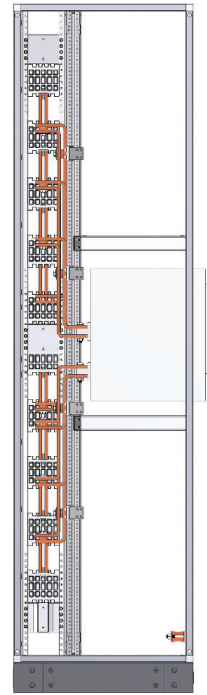

Side view

Incomer 2

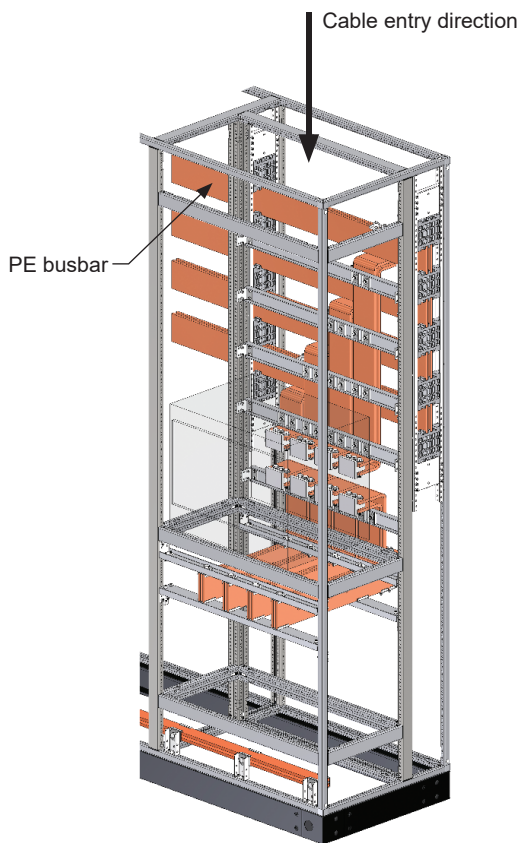

Front view

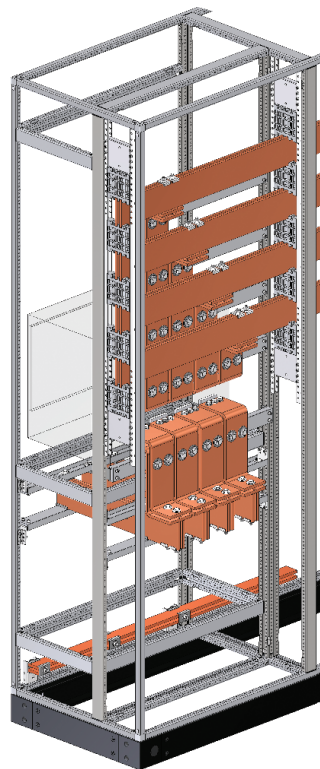

Rear view

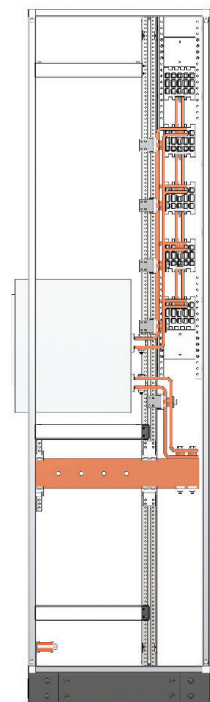

Side view

* Separation plates, Doors, Covers are not shown

"L" SHAPE PANEL EXAMPLE

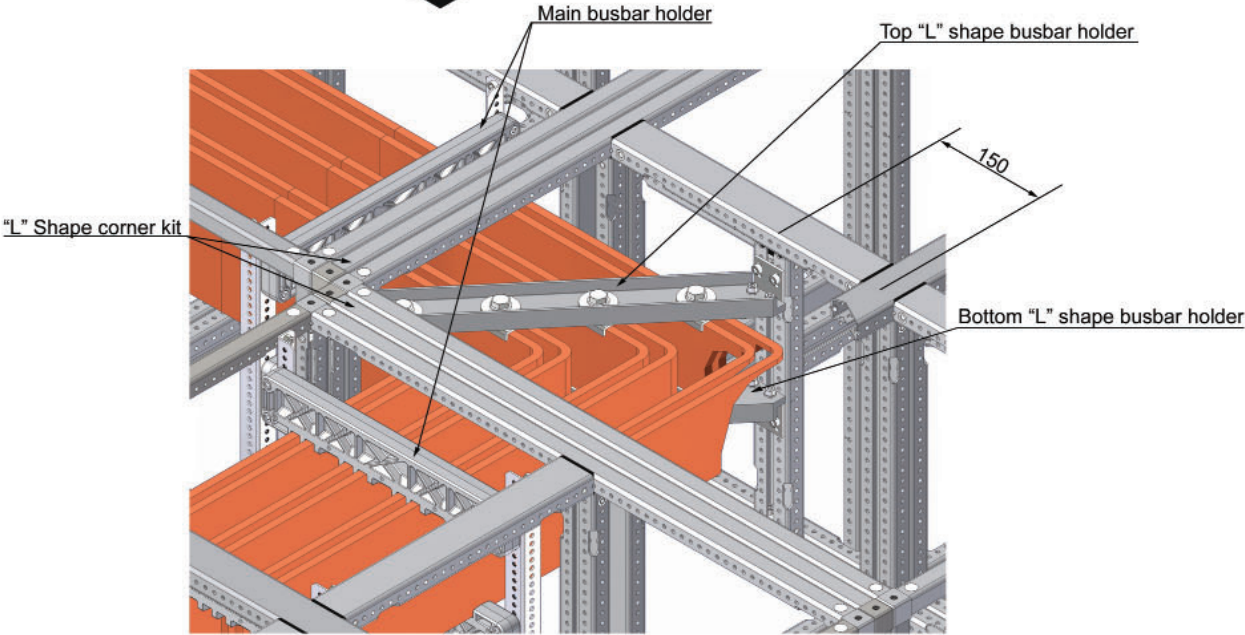
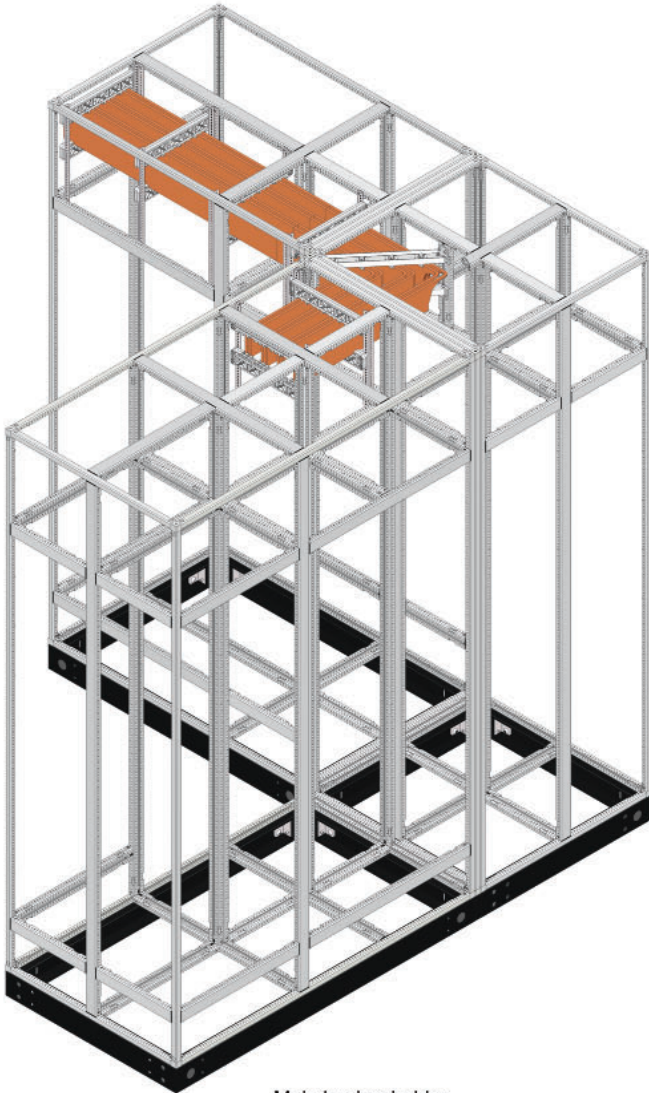

* Separation plates, Doors, Covers are not shown

TECHNICAL PROPERTIES

- Type of Main Busbar Holder - OMH 400
- Quantity of Cu bars - 02 Cu bars per phase

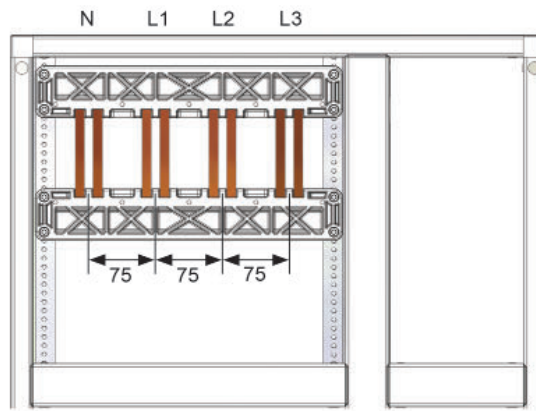

Main Busbar arrangement

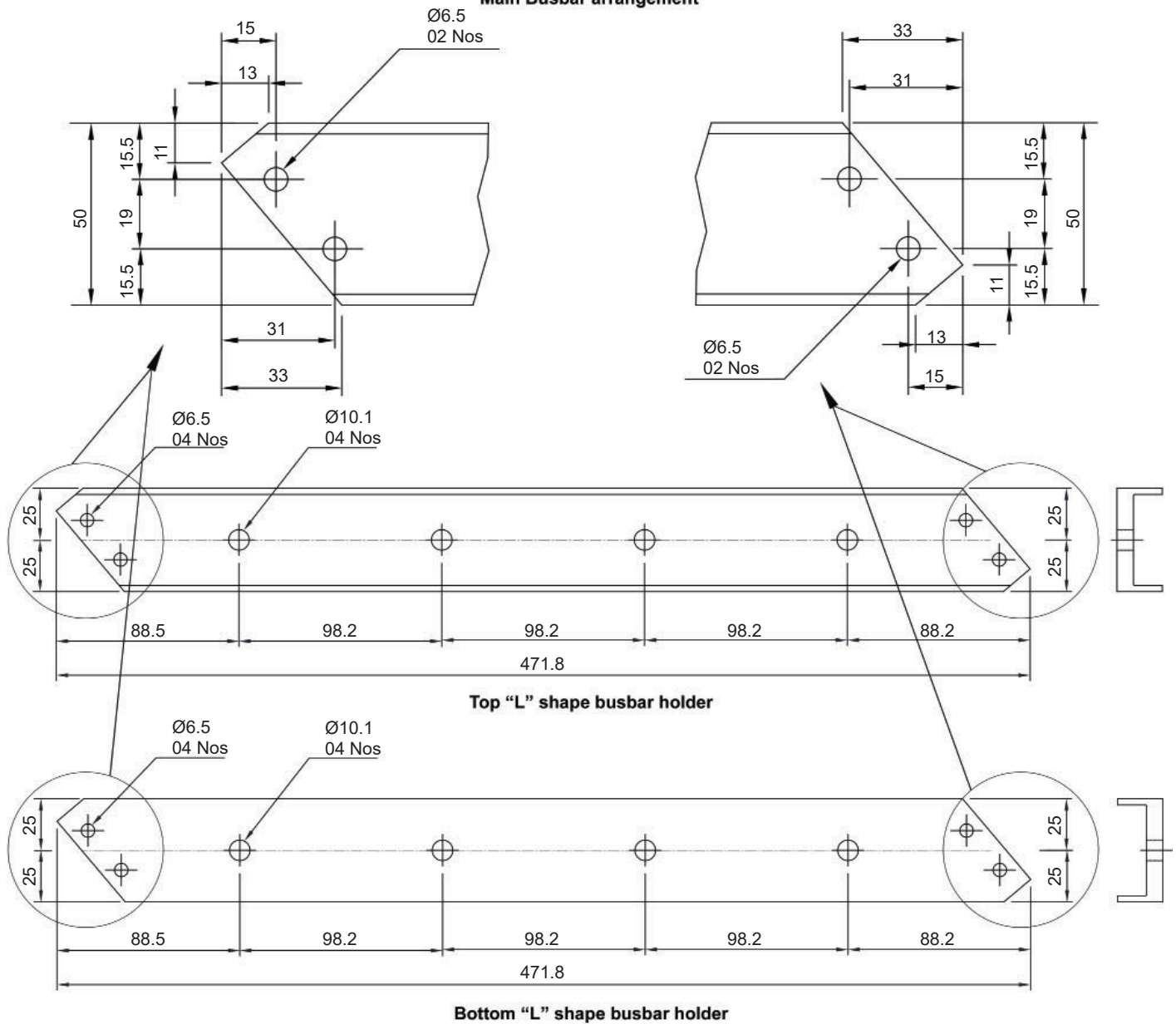

Note : To manufacture "L" shape busbar holders please use Isolation Profile (20650).

TECHNICAL PROPERTIES

Type of Main Busbar Holder - OMH 600

Quantity of Cu bars - 02 Cu bars per phase

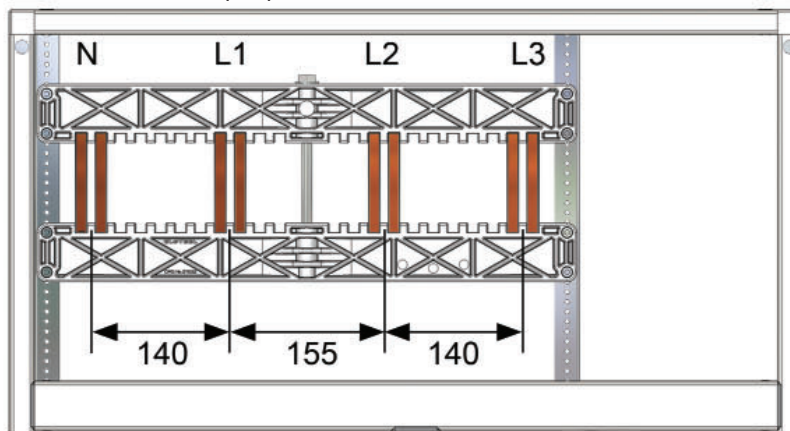

Main Busbar arrangement

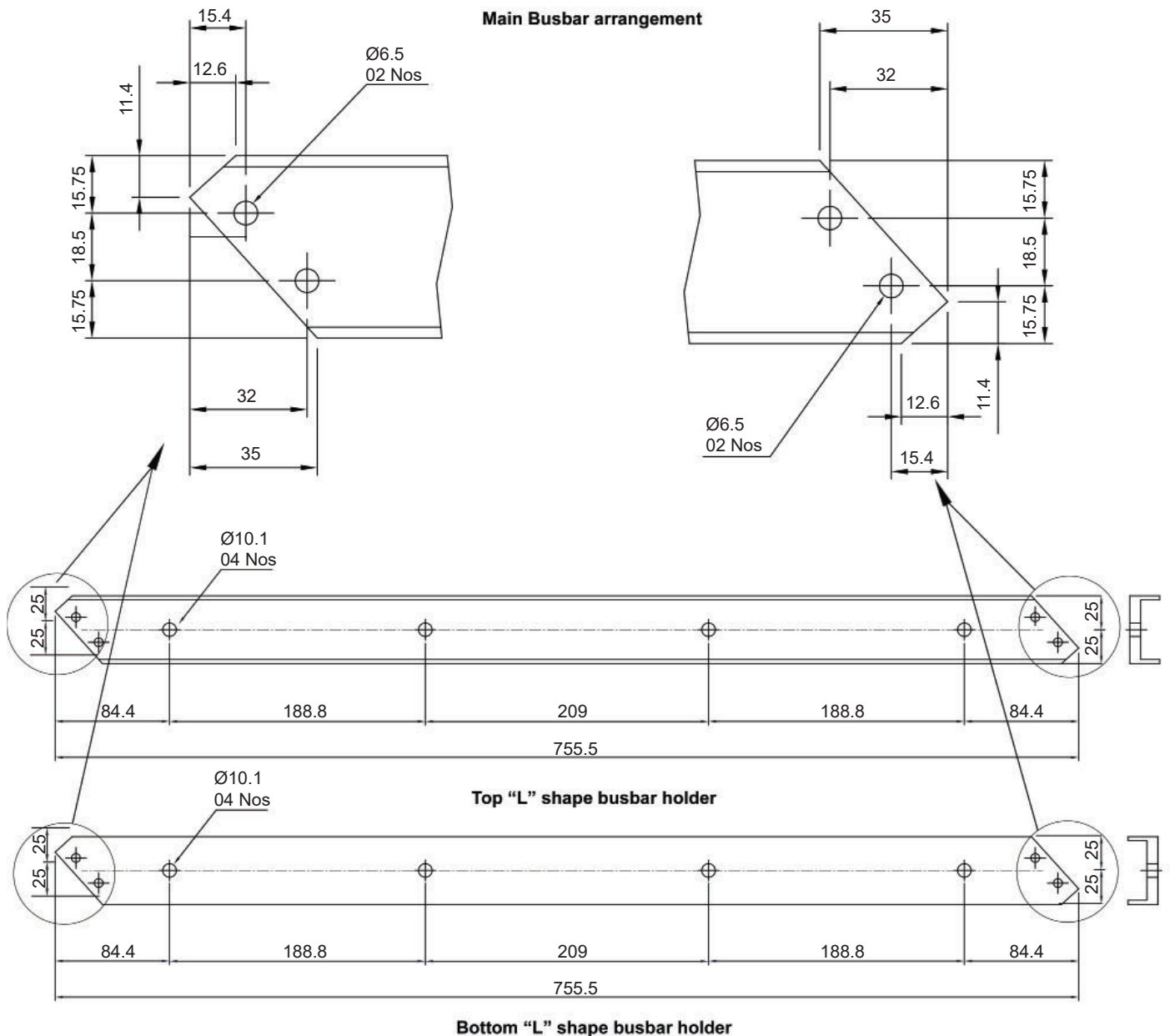

Note : To manufacture "L" shape busbar holders please use Isolation Profile (20650).

TECHNICAL PROPERTIES

Type of Main Busbar Holder - OMH 600

Quantity of Cu bars - 03 Cu bars per phase

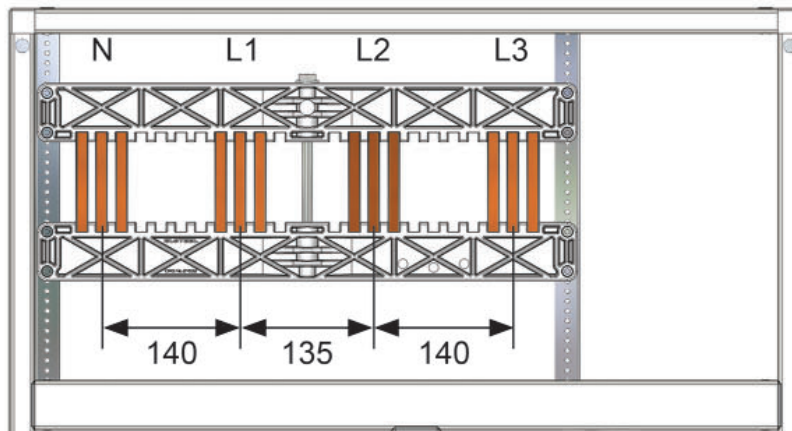

Main Busbar arrangement

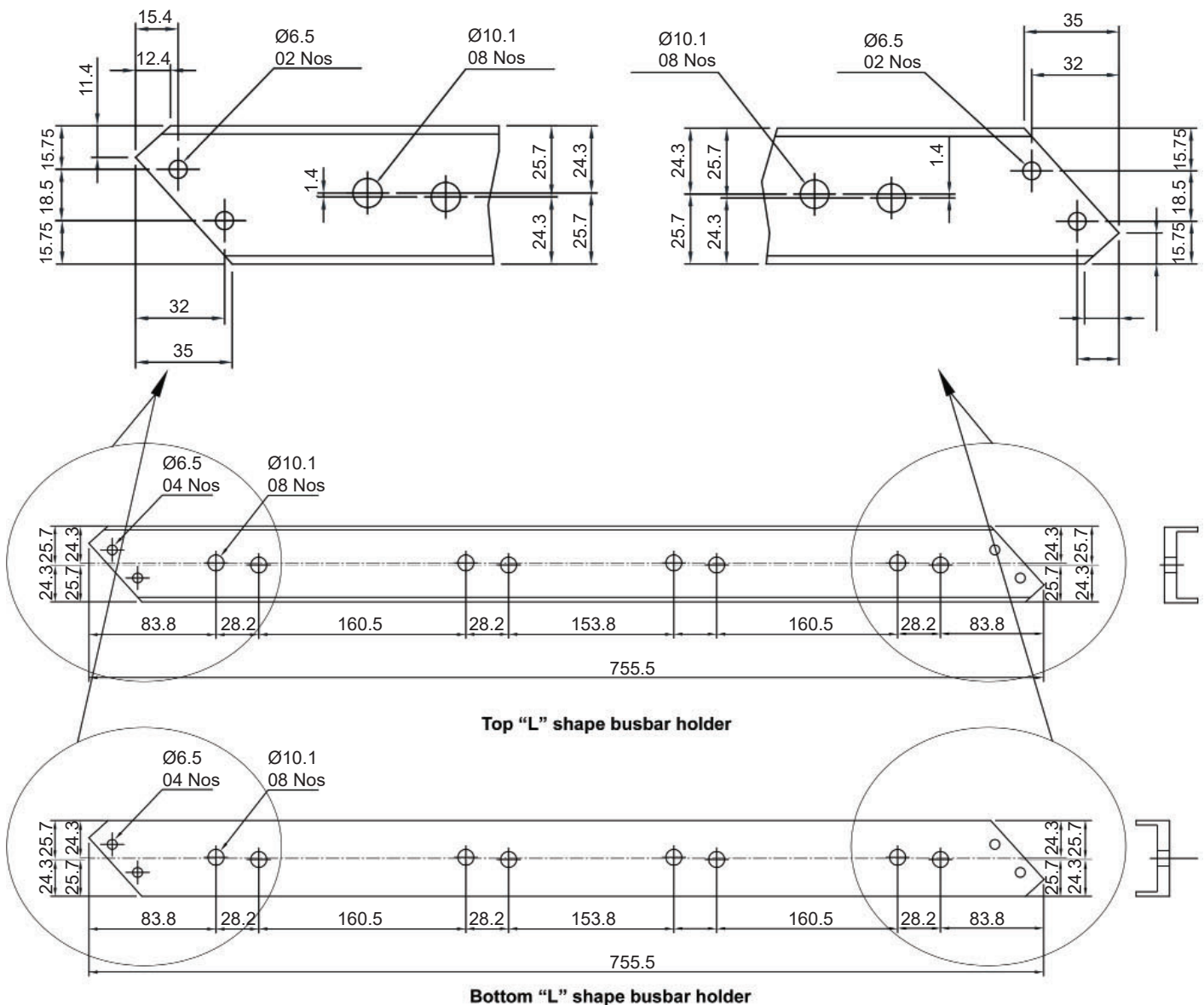

Note : To manufacture "L" shape busbar holders please use Isolation Profile (20650).

TECHNICAL PROPERTIES

- Type of Main Busbar Holder - OMH 800
- Quantity of Cu bars - 02 Cu bars per phase

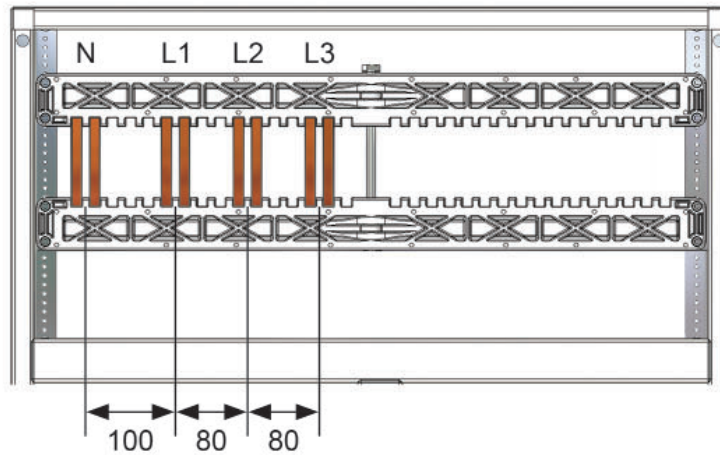

Main Busbar arrangement

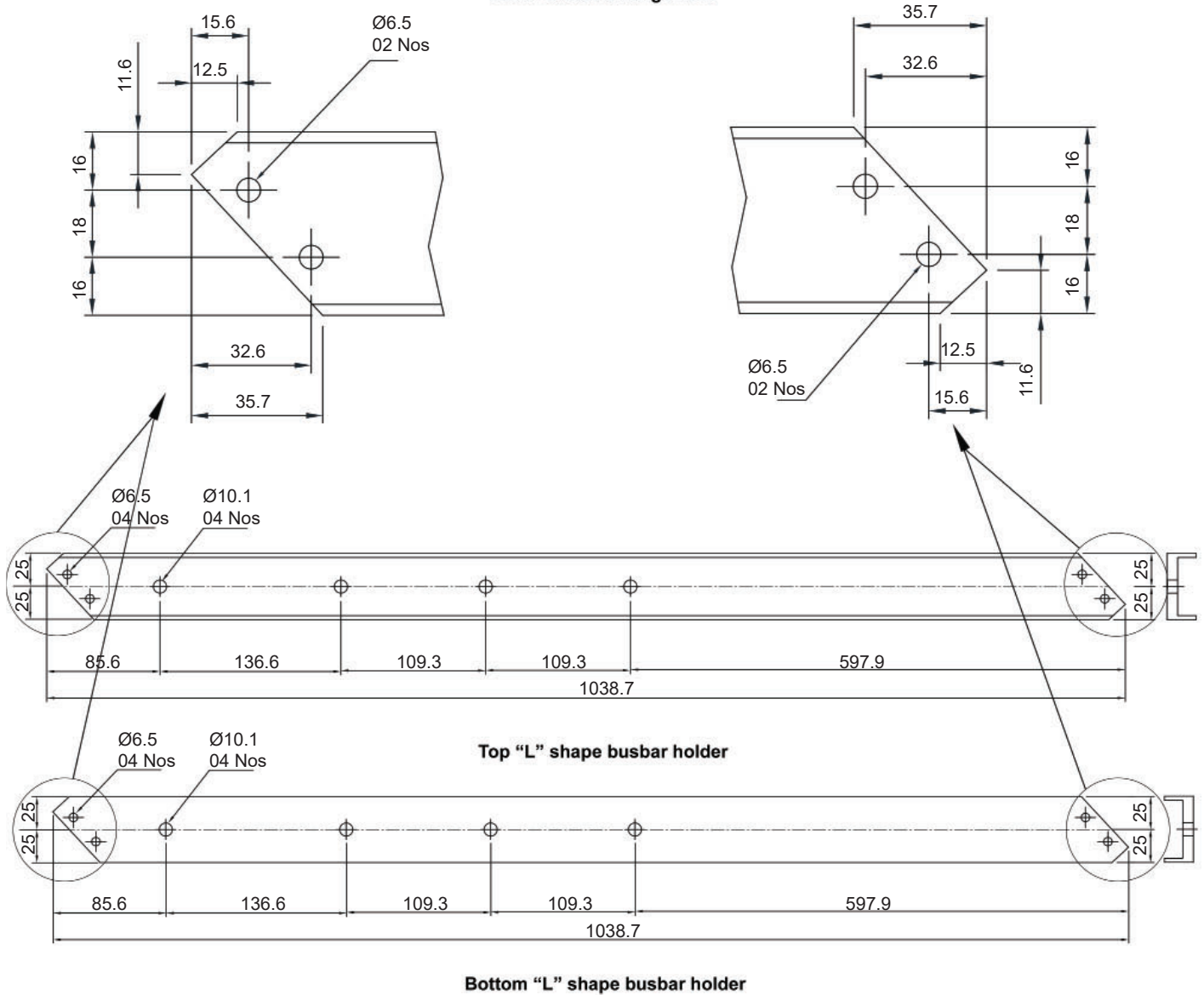

Note : To manufacture "L" shape busbar holders please use Isolation Profile (20650).

TECHNICAL PROPERTIES

- Type of Main Busbar Holder - OMH 800
- Quantity of Cu bars - 03 Cu bars per phase

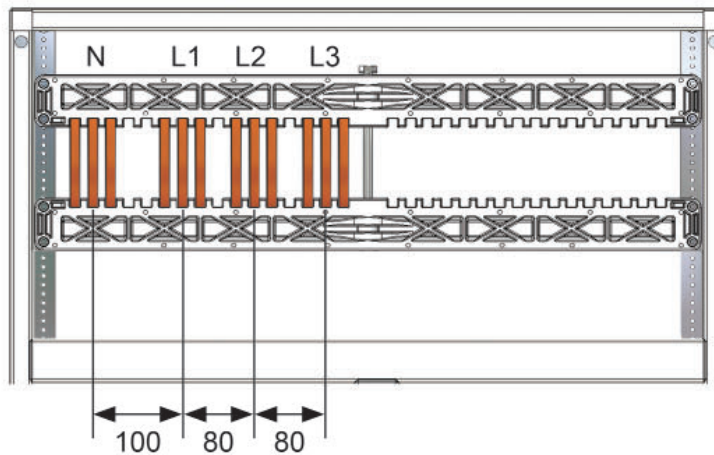

Main Busbar arrangement

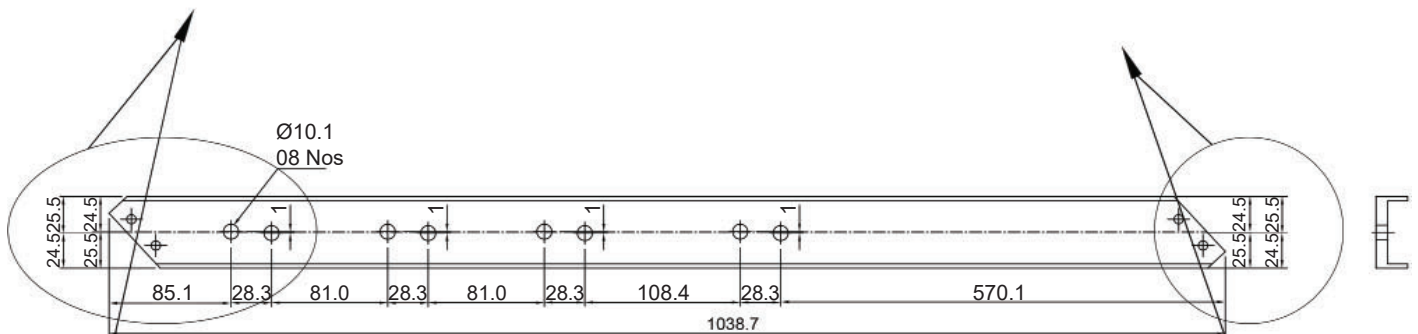
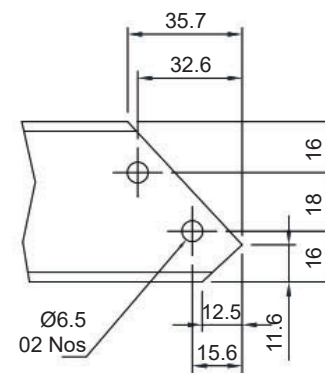
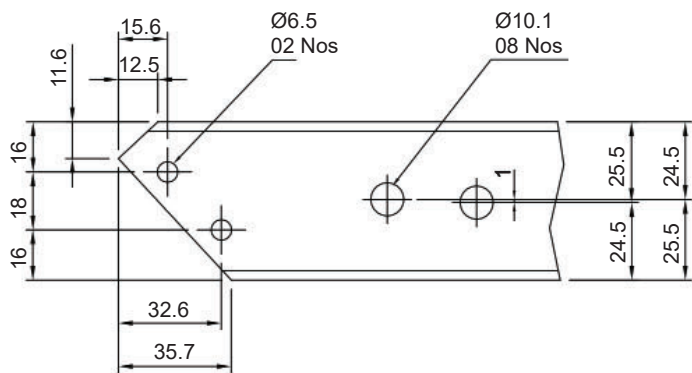

Top "L" shape busbar holder

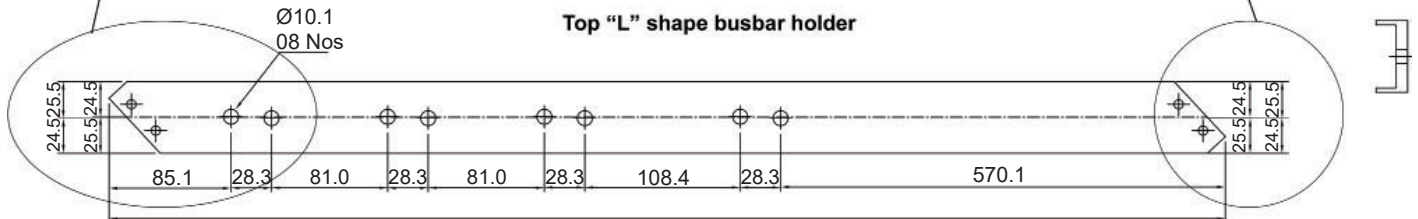

Bottom "L" shape busbar holder

Note : To manufacture "L" shape busbar holders please use Isolation Profile (20650).

TECHNICAL PROPERTIES

- Type of Main Busbar Holder - OMH 800
- Quantity of Cu bars - 04 Cu bars per phase

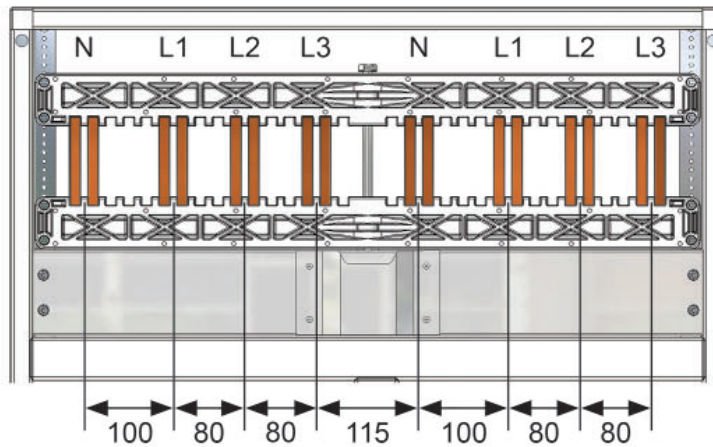

Main Busbar arrangement

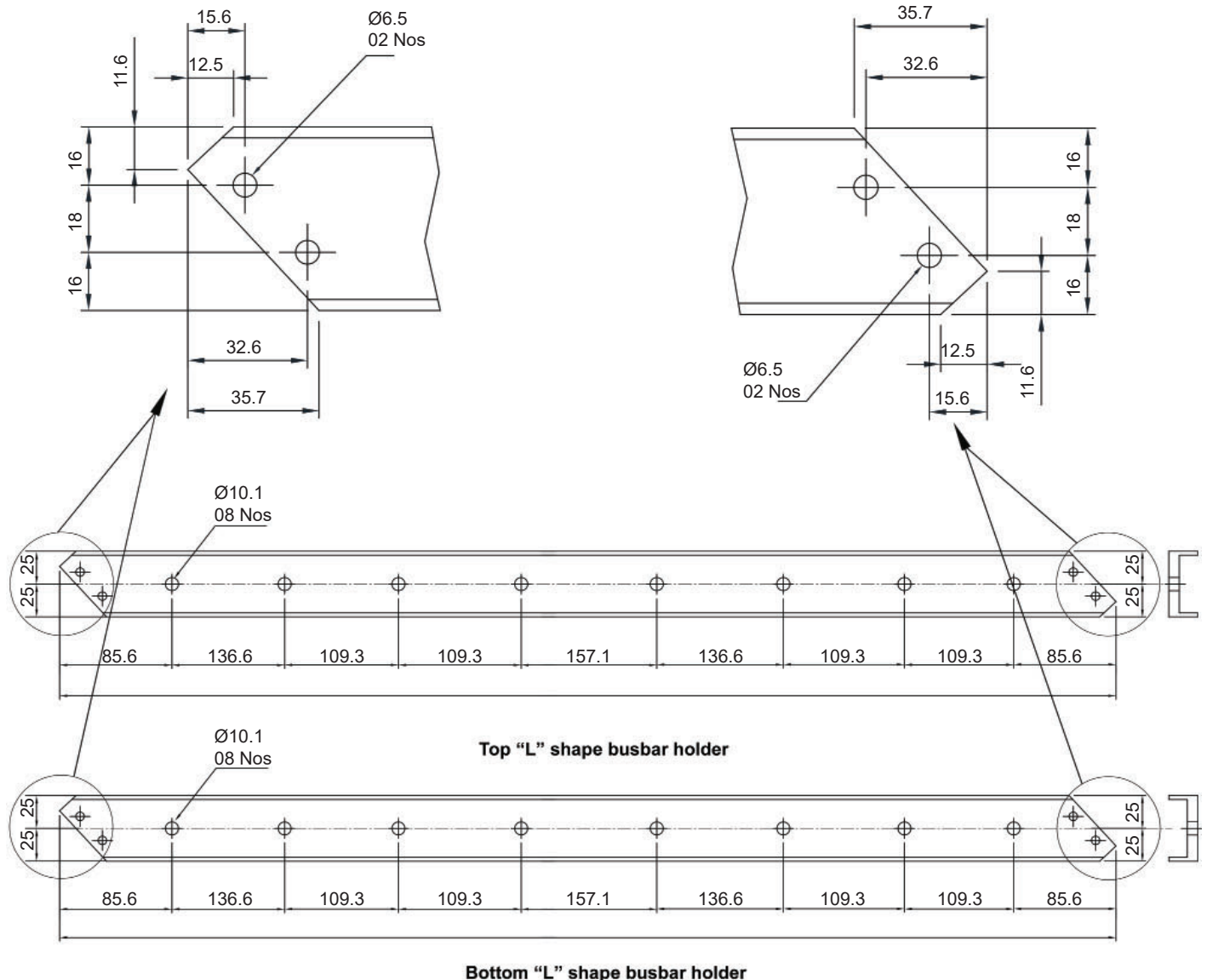

Note : To manufacture "L" shape busbar holders please use Isolation Profile (20650).

TECHNICAL PROPERTIES

- Type of Main Busbar Holder - OMH 800
- Quantity of Cu bars - 06 Cu bars per phase

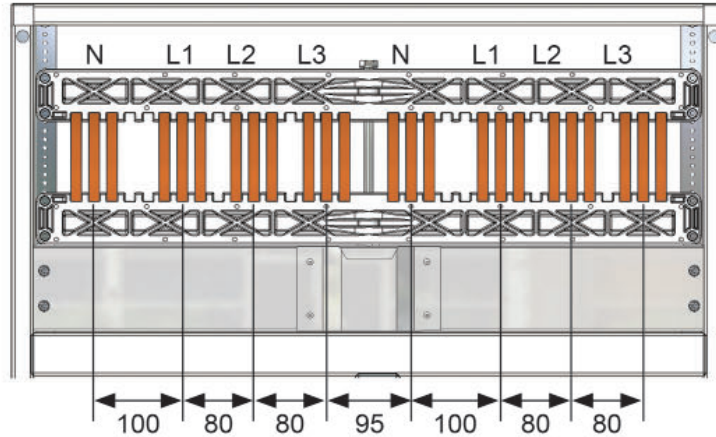

Main Busbar arrangement

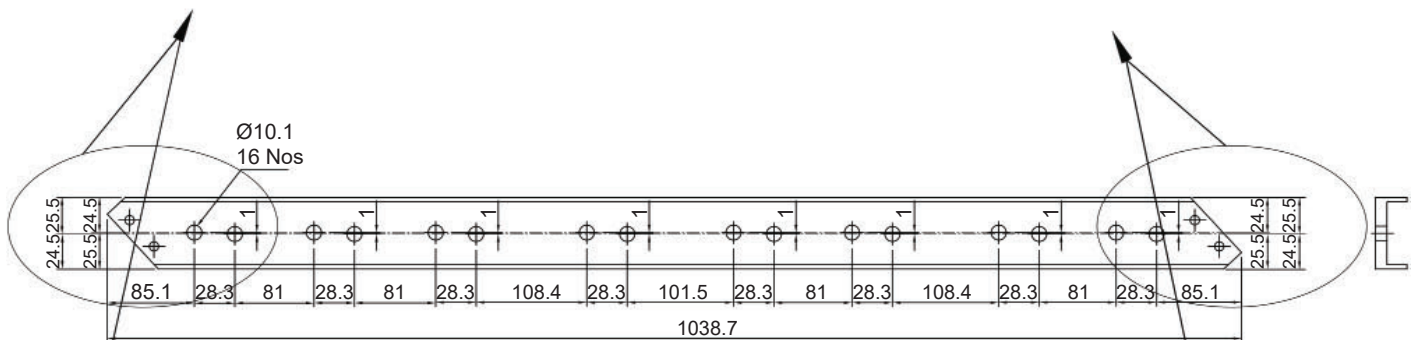
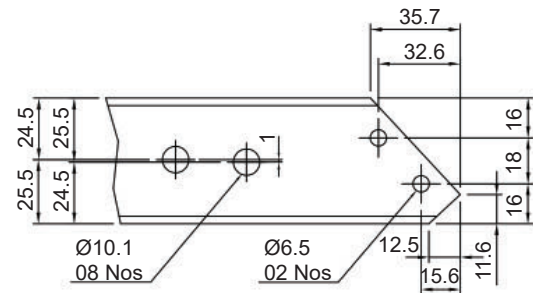
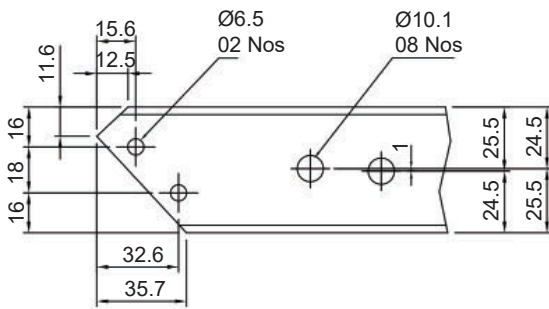

Top "L" shape busbar holder

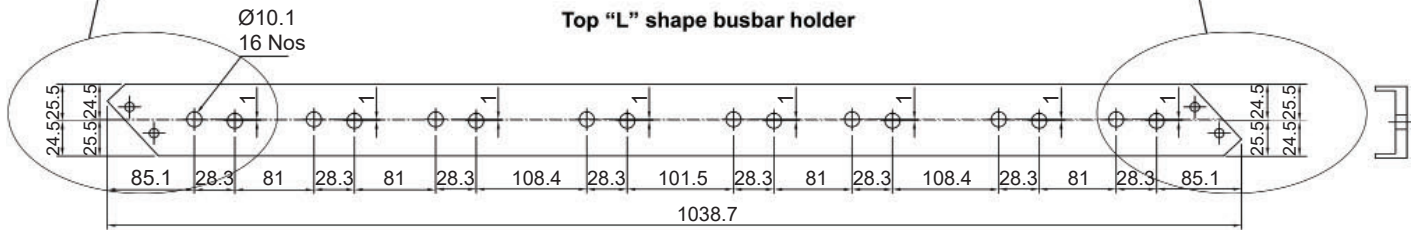

Bottom "L" shape busbar holder

Note : To manufacture "L" shape busbar holders please use Isolation Profile (20650).

①

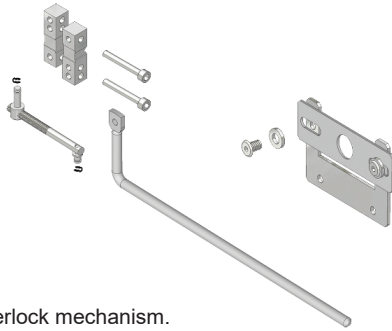

Parts of the interlock mechanism. Connect the two sheet metal parts using two screws and washers.

②

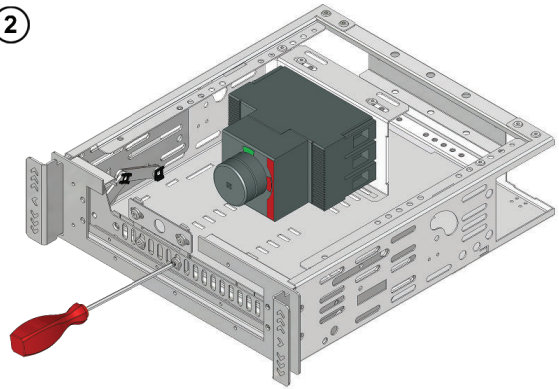

Attach the bracket to the interlock rail with screws and washers.

③

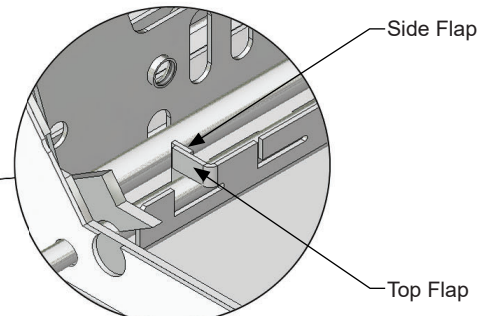
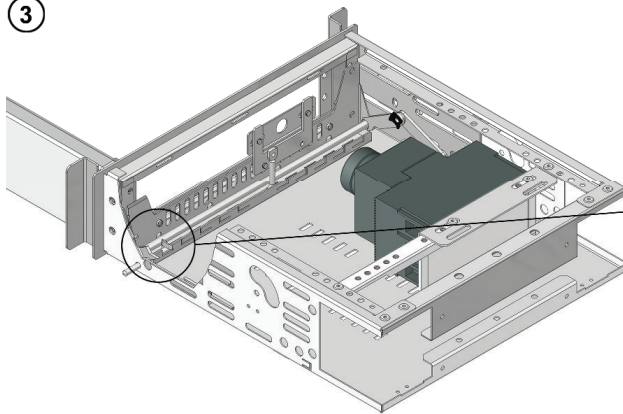

Insert the lock rod into the interlock rail and bend the "flaps" (top and side flaps) of the interlock rail.

④

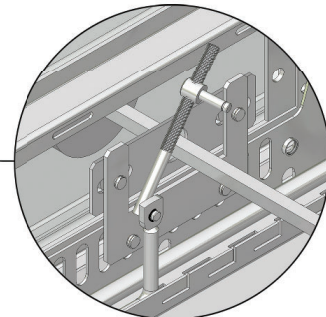
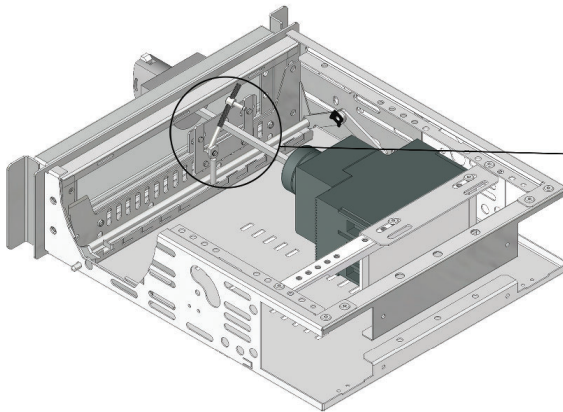

Insert the breaker rod through the bracket and secure to the breaker. Attach the threaded flexible arm to the lock rod. The short pin must be inserted in the lock rod.

⑤

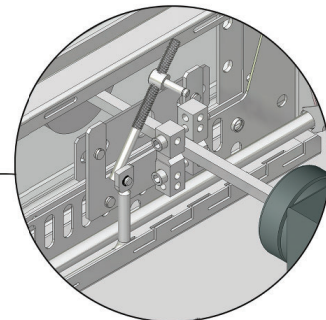
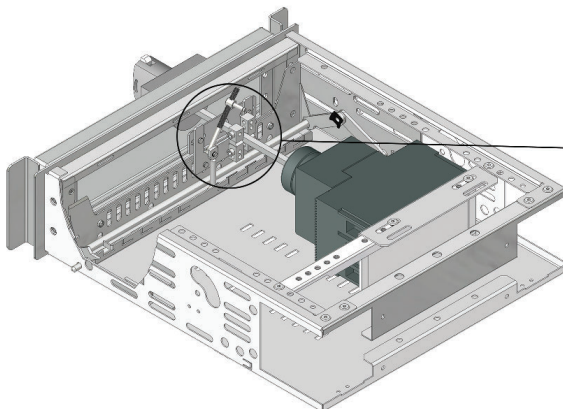

Attach the tightening block to the breaker rod as shown. The tightening block must align with the threaded flexible arm.

6

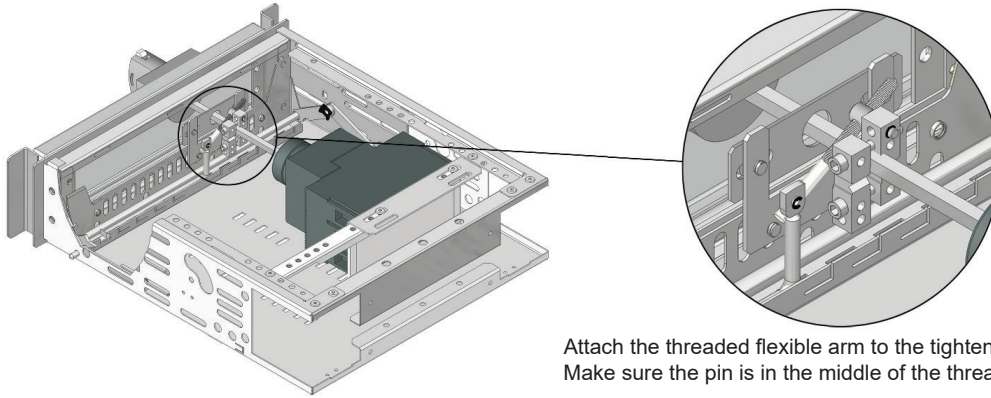

Attach the threaded flexible arm to the tightening block as shown. Make sure the pin is in the middle of the threaded part of the flexible arm.

7

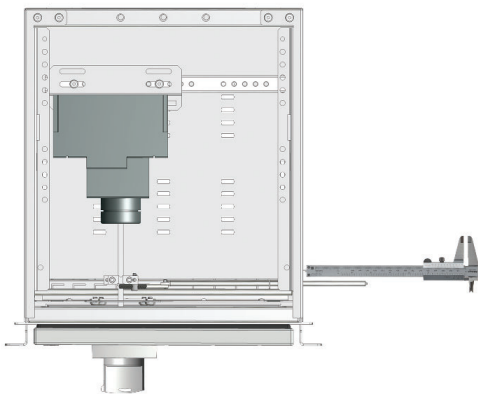

Turn the rotary handle to the ON position. Make a mark on the bended interlock rod approximately 5-7mm from the edge.

8



Remove cir-clip of the shorter pin and take out the bended interlock rod. Cut at the mark. Make sure to chamfer (atleast 2mm) the end of the rod.

9

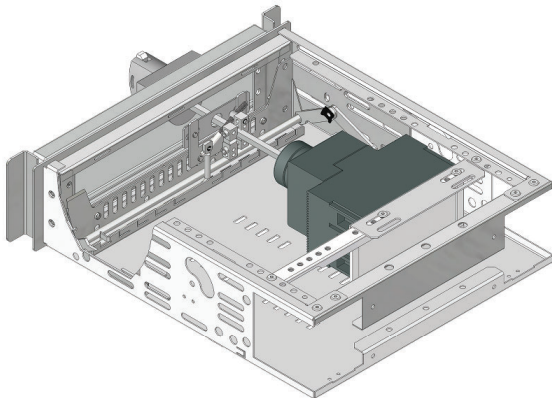

Put the bended interlock rod back into the interlock rail and secure it with the cir-clip.

10

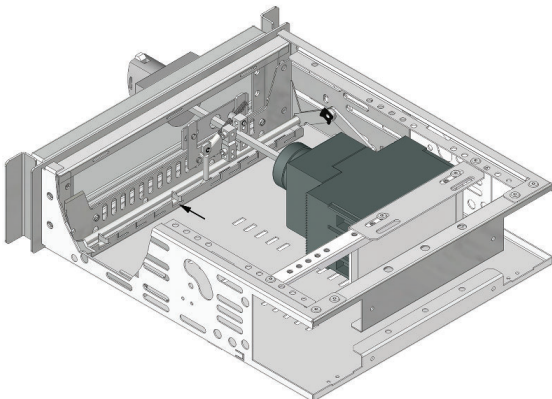

Now bend the rest of the "lock rod guiding flaps" (top & side flaps) as needed for smooth operation of interlock mechanism.

- There is a very good animation on www.elsteel.com under our login section that shows exactly how to do this if you need more details.

POSSIBLE TECHNO MODULE LIGHT ARRANGEMENT FOR TYPICAL MCCB UP TO 630A

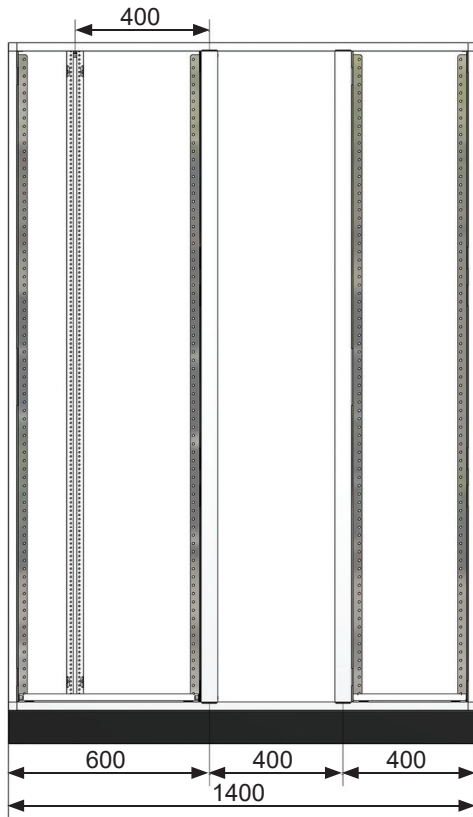

Front View

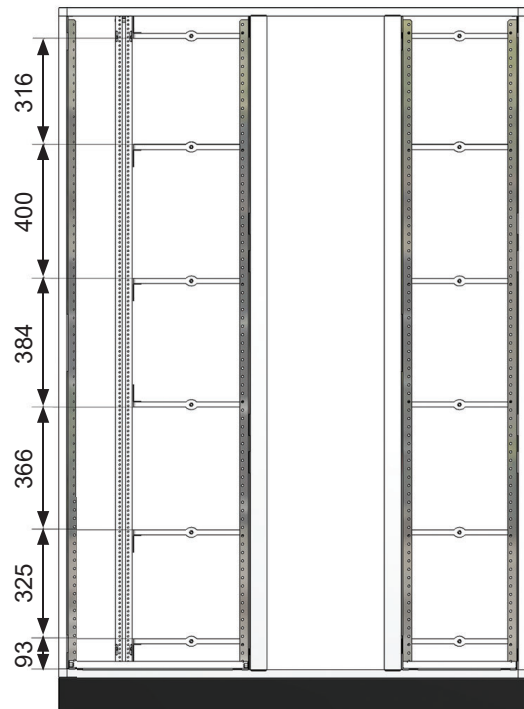

Front View

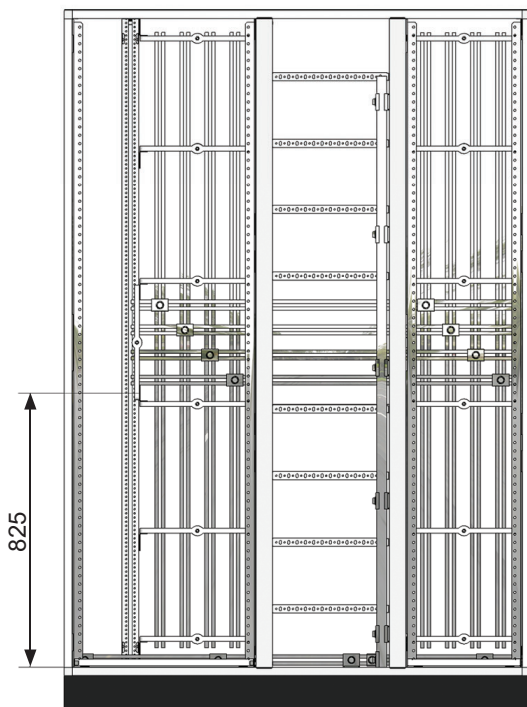

Front View

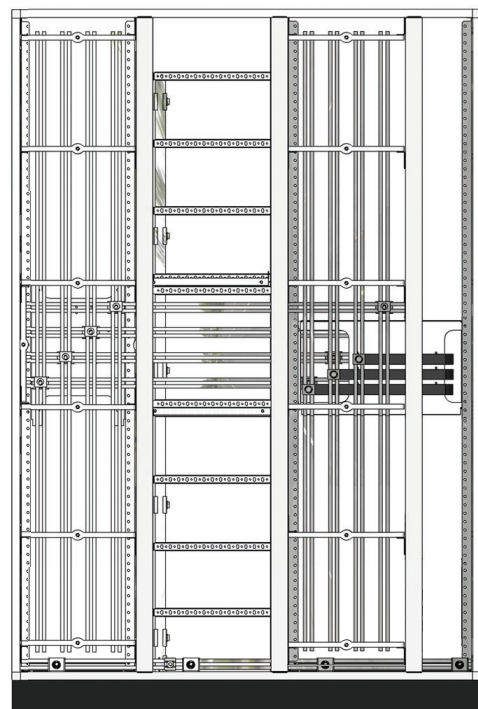

Rear View

POSSIBLE TECHNO MODULE LIGHT ARRANGEMENT FOR TYPICAL MCCB UP TO 630A

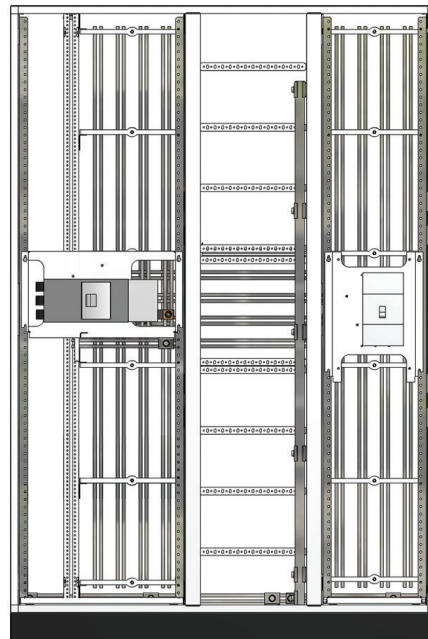

Front View

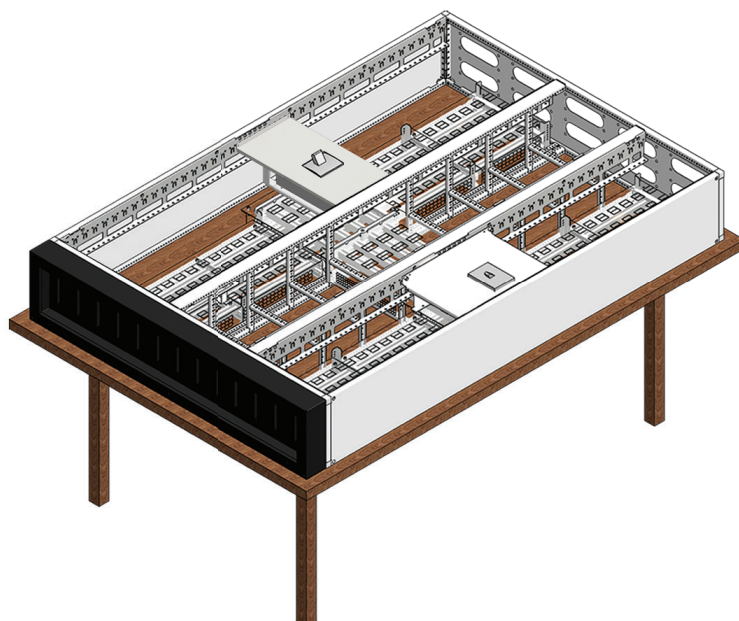
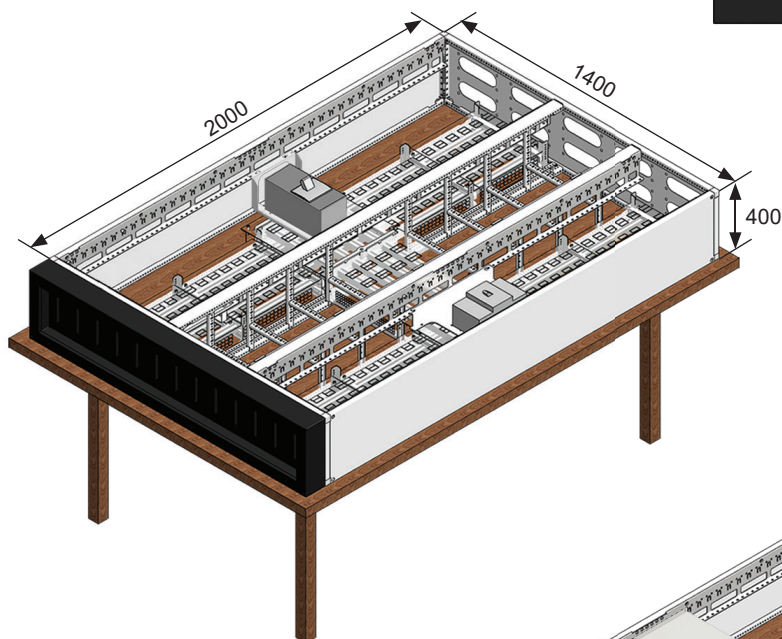

POSSIBLE TECHNO MODULE LIGHT ARRANGEMENT FOR TYPICAL MCCB UP TO 250A

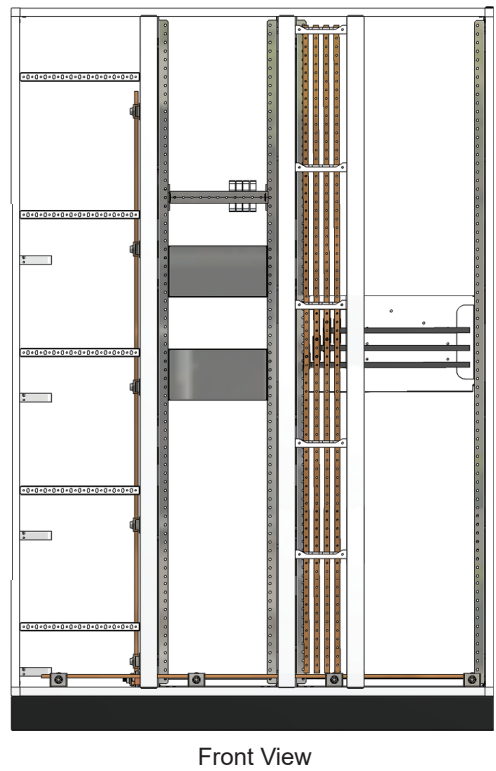
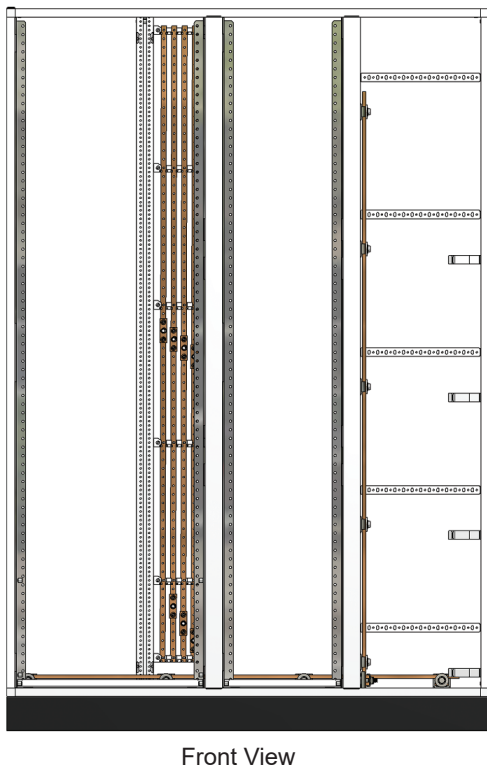
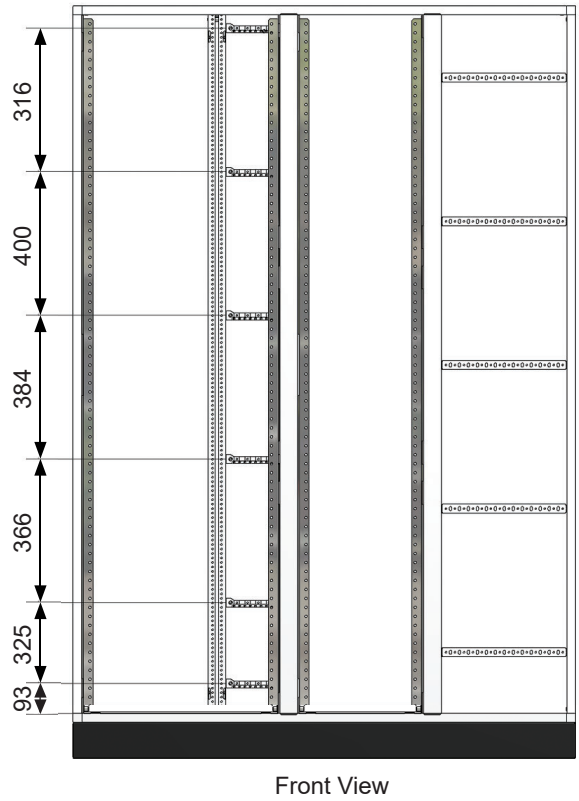
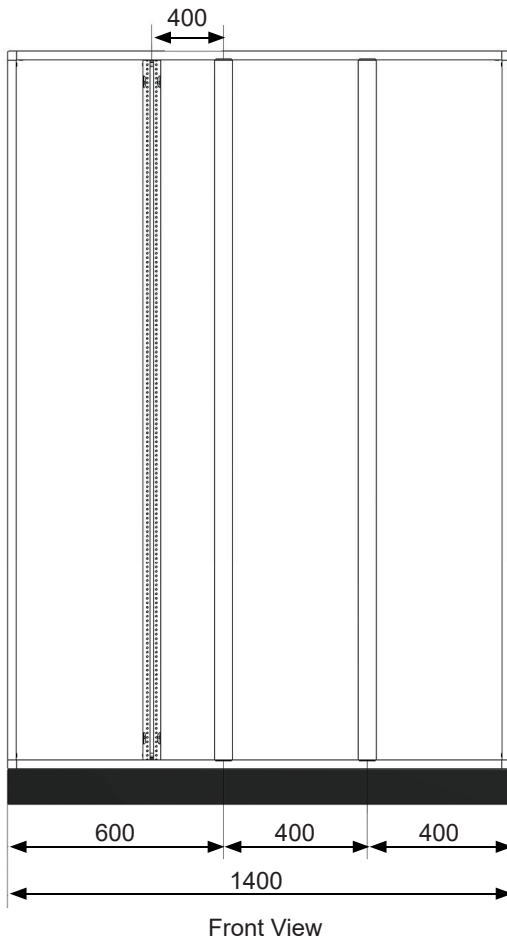

POSSIBLE TECHNO MODULE LIGHT ARRANGEMENT FOR TYPICAL MCCB UP TO 250A

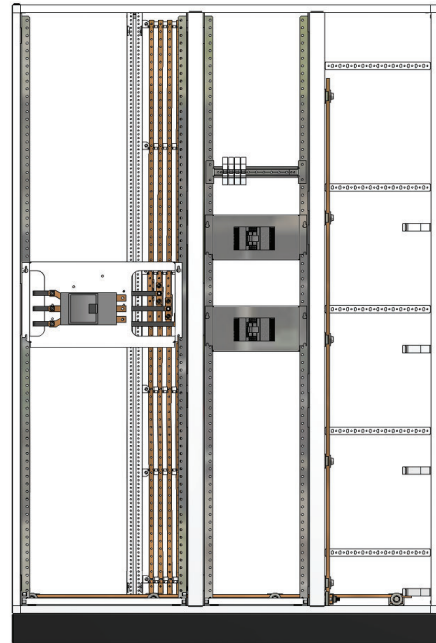

Front View

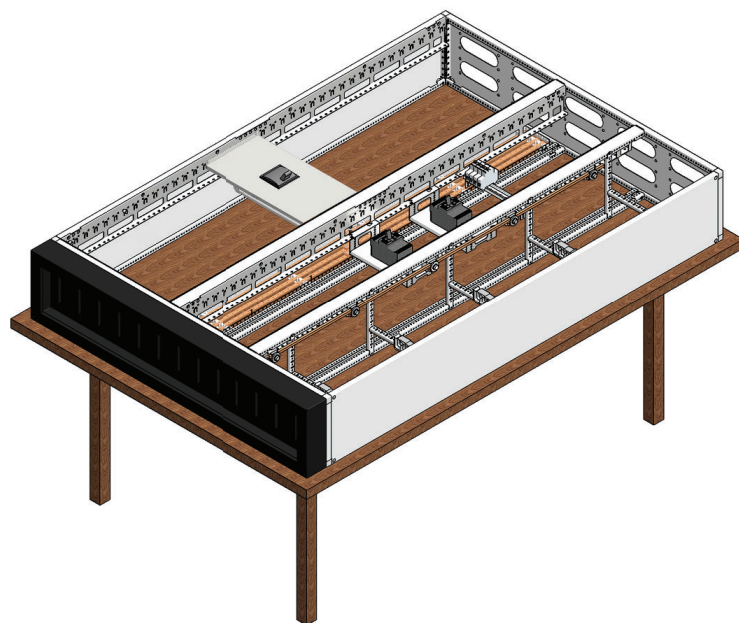
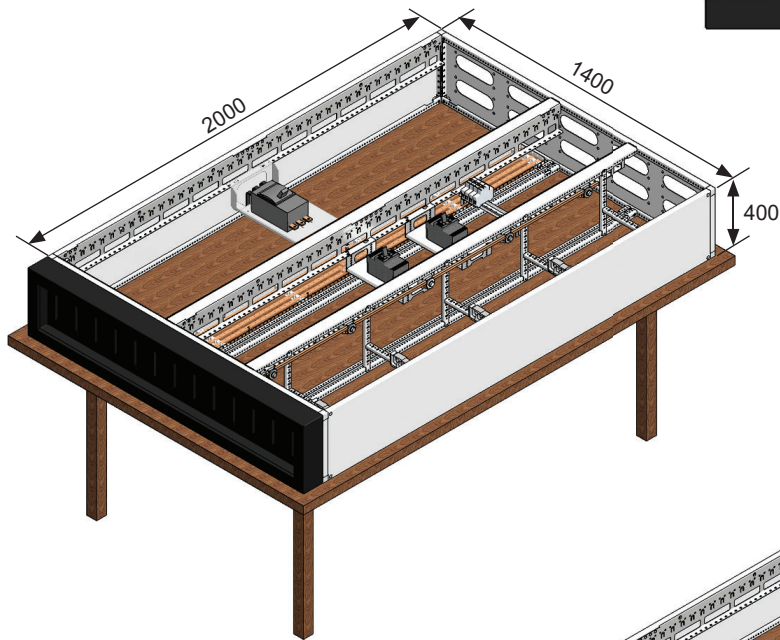

MODULAR
ELSTEEL
ENCLOSURES



100% Danish
Technology

Møllevej 9 C · 2990 Nivå
Denmark
Tel +45 49 22 33 44
elsteel@elsteel.dk
www.elsteel.com